



DOZER

SHANTUI
VALUE THAT WORKS

LET'S MAKE
CONSTRUCTION EASIER



SHANTUI
VALUE THAT WORKS

Shandong Shantui Construction Machinery Imp.& Exp.Co.,Ltd

TEL: +86-537-2909336

FAX: +86-537-2311219

Email: trade@shantui.com

Add: Add: 4th Floor, Shantui office Building(Shantui Industry Park), No.58 Highway G327,
Jining City, Shandong Province, China

Engine	WeichaiWP10G240E341
Rated Power	178kW/2200rpm
Operating weight	18200 kg

SDW24
WHEEL DOZER



SDW24 Wheel Dozer(Tier3)

SDW24 wheel dozer is a specialized developed for harsh working conditions. It has long and wide body, good stability and tough appearance. The blade can be tilted. It has strong adaptability to working conditions and high operation efficiency. It is equipped with standard pilot control. WH blade is optional for grabage landfilling jobs.

Product Features



Weichai EFI engine, with low noise, China III stage emission, low fuel consumption and stable power. Electronic control, equipped with 93 type air filter whose air filtering effect is better, matched with fixed shaft, high efficiency.

The front and rear frame, boom and blade adopt reinforced design, which can bear the over load caused by heavy duty jobs. The new connection structure of tilt cylinder increases adaptability and reliability.



New luxury cab, optional with ROPS&FOPS, standard equipped with cold and warm air conditioning; safe and comfortable; wide vision; sound insulation and noise reduction.

The main lamps are equipped with protective cover, which can effectively prevent the damage of falling objects and flying stones to lamps and glass.



Step motor type instrument panel with fault alarm and fault self diagnosis functions; With maintenance free battery, waterproof connector

The side door is opened by spreading wings, which has large maintenance space and convenient



Working hydraulic system adopts single pilot joystick, which is light and flexible, and can reduce the driver's fatigue

The new type radiator and straight tube fin structure are adopted to further improve the anti blocking ability and heat dissipation effect.



A variety of sound insulation and noise reduction measures are adopted, and the noise near the ear is better than the national compulsory standard.

Dimension

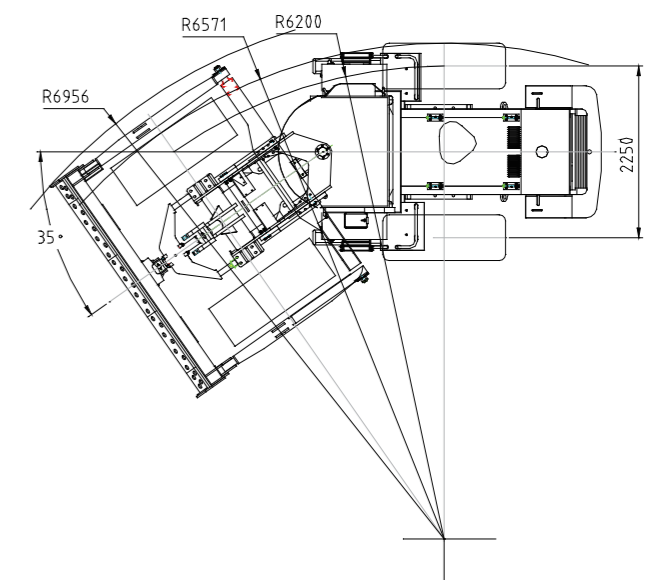
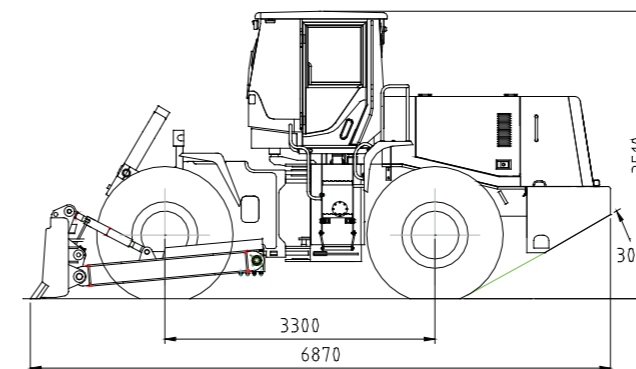

Specification

Item	Model	SDW24	Item	Model	SDW24
Overall L*W*H (mm)		6870*3500*3510	Blade back tilting angle (°)		7
Wheel base (mm)		3300	Blade cutting angle (°)		55
Wheel tread (mm)		2250	Blade height*width (mm)		1165*3500
Operating weight (kg)		18200	Travelling speed		Fr 4 speed, Re 4 speed
Min ground clearance (mm)		350	Gears		4
Turning angle (°)		35	Forward (km/h)		8/15/25/40
Max traction (kn)		160	Reverse (km/h)		8/15/25/40
Blade max lifting height (mm)		985	Rated power (kw)		178
Blade max digging depth (mm)		388	Speed (r/min)		2200
Blade max tilting height (mm)		450			
Max gradability		30			