

I N S T R U C T I O N M A N U A L

D E N Y O

D I E S E L G E N E R A T I N G S E T S

Before using, be sure to read this manual for the sake of safety.

Be sure to observe the items under symbol marks "⚠ WARNING"
and "⚠ CAUTION" for the sake of safety.

Always keep this manual at your machine for the sake of safety.

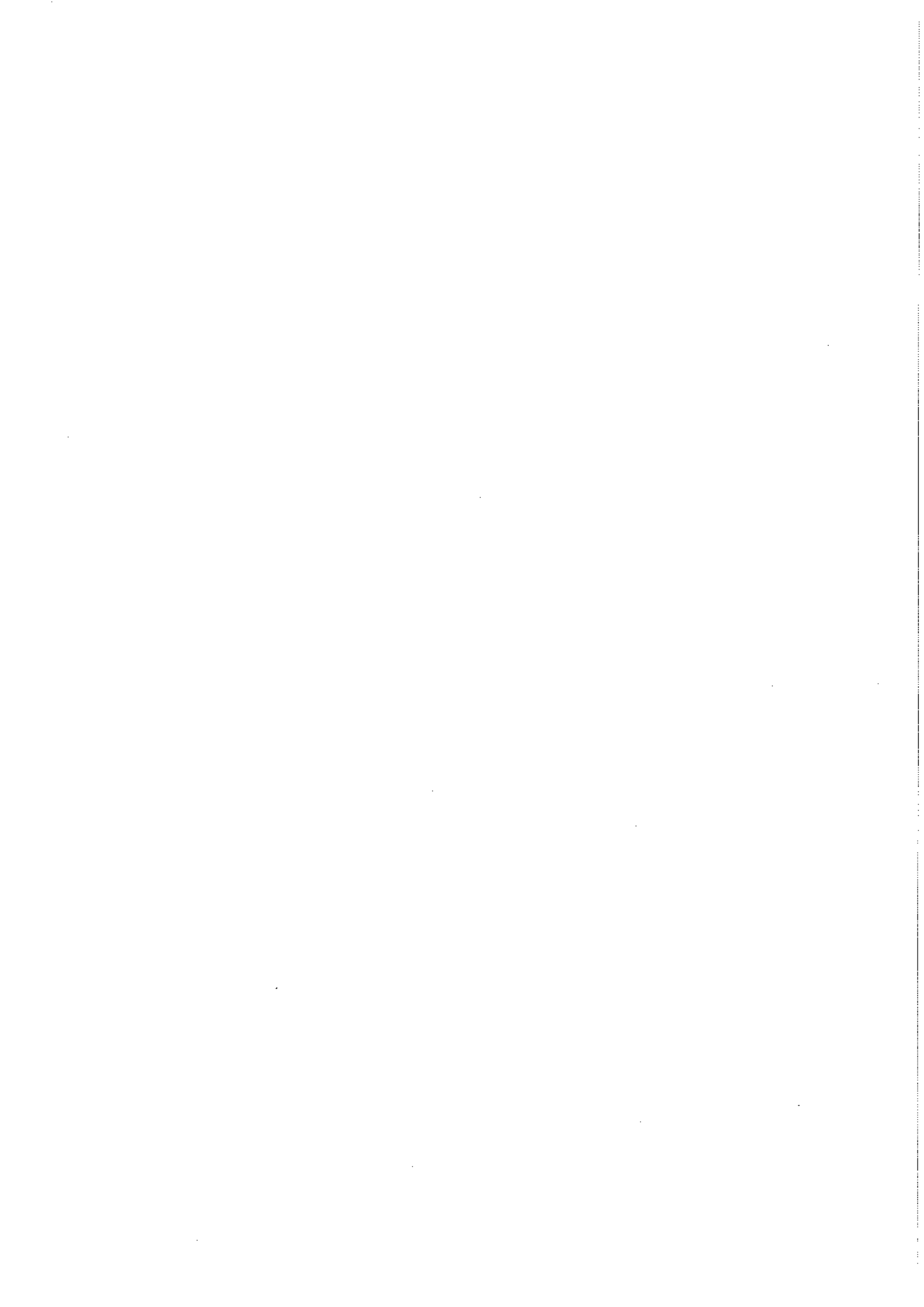

M O D E L : D C A - 6 0 0 S P K



FORWARD

- * Your machine is a portable type diesel generating set.
(Specifications: See p.79)
- * Do not install, operate or repair this machine without reading this operating manual.
- * This generator set (machine) must be operated by a person having sufficient knowledge and skill for the sake of safety.

Notes on instruction manual

- * This instruction manual explains correct operation and maintenance of the machine to ensure its performance.
Incorrect handling of the machine may lead to a serious injury or decease.
Before using, be sure to read this manual carefully.
Particularly, the items under " Safety precautions" (See p.1 to p.10),
"  WARNING" and "  CAUTION" must be read thoroughly.
- * Keep this manual in the case behind the rear door for future reference.
- * Read the contents of the warranty card attached to the machine.

- If this manual becomes illegible by spot or damage, contact distributor or our office to get new manual.

- Contents -

1.	Safety Precautions	1
2.	Construction	11
2-1	Outline and part names	11
2-2	Operating panel, control panel and part names	12
2-3	Meters	13
2-4	Use of switches and controllers	18
2-5	Electronic governor controller	22
3.	Transportation and installation	23
3-1	Transportation of machine	23
3-2	Installation of machine	24
4.	Connecting the load	26
4-1	Method for selecting output voltage	26
4-2	Cables to be used	28
4-3	Connecting the load	29
4-4	Grounding	32
5.	Operation	34
5-1	Checking prior to operation	34
5-2	Startup	40
5-3	Starting in the cold weather	43
5-4	Handling during operation	45
5-5	Shutdown	46
5-6	Protection device	47
6.	Parallel operation	48
6-1	Preparation for parallel operation	48
6-2	Parallel operation	49
6-3	Precautions	51
6-4	Shut down	52
7.	Lubrication, cooling water and fuel	53
7-1	Engine oil	53
7-2	Cooling water	54
7-3	Fuel	54
7-4	Fuel piping selector	55
8.	Handling of battery	57
8-1	Caution on battery charge	58
8-2	Connection of booster cable, and installation	59
9.	Periodical checking and maintenance	60
9-1	Maintenance schedule	63
9-2	Checking/every 250 hours	64
9-3	Checking/every 500 hours	69
9-4	Checking/every 1000 hours	71
9-5	Table of periodical maintenance and checking	73
10.	Troubleshooting	74
11.	Long-term storage	78
12.	Service data	79
12-1	Specifications	79
12-2	Outline drawing	80
12-3	Generator connection diagram	81
12-4	Engine wiring diagram	82
13.	Options instruction manual	83
13-1	Automatic oiler	83
13-2	Earth leakage relay	85

1. Safety Precautions

In order to ensure safe operation, the following symbols are used for explanation of the machine operation.

The following symbols, found throughout this manual, alert you to potentially dangerous conditions to the operator, service personnel, or the equipment.

⚠ WARNING: This symbol refers to a hazard or unsafe practice which can result in severe personal injury or death.

⚠ CAUTION: This symbol refers to a hazard or unsafe practice which can result in personal injury or product or property damage.

[Note] : This symbols show handling precautions for effective operation and many years of satisfactory operation.

Some of the items shown by " ⚠ CAUTION" may also cause death or serious injury.

Be sure to observe all the items, as they are important for safe operation.

- * If the machine is used by an outsider, you are requested to explain him correct handling and advise him to read this instruction manual carefully.
- * Do not modify the machine at your discretion, as it affects the safety, performance or the life of the machine.
- * If the machine is modified or it is used incorrectly against this manual or unauthorized parts are used, the warranty of manufacturer will become invalid.

Safety label

Safety labels are attached to the following positions of the machine.

- * Keep these safety labels clean at all times.
- * When safety labels are spoiled or lost, contact distributor or our office specifying the nameplate No. shown below and ask for new ones.

No.	Parts name	Parts number	No.	Parts name	Parts number
1	Safety instruction	B9211 0040	6	Warning : moving part	B9040 0040
2	Warning : exhaust gas	B9042 0000	7	Warning : fire accident	B9045 0000
3	Warning : output voltage	B9311 0050	8	Caution : high temp	B9040 0030
4	Warning : electric leakage	B9111 0040	9	Warning : radiator cap	B9041 0010
5	Warning : electrical shock	B9311 0060	10	Warning : house wiring	B9111 0030
			11	Caution : muffler	B9111 0020

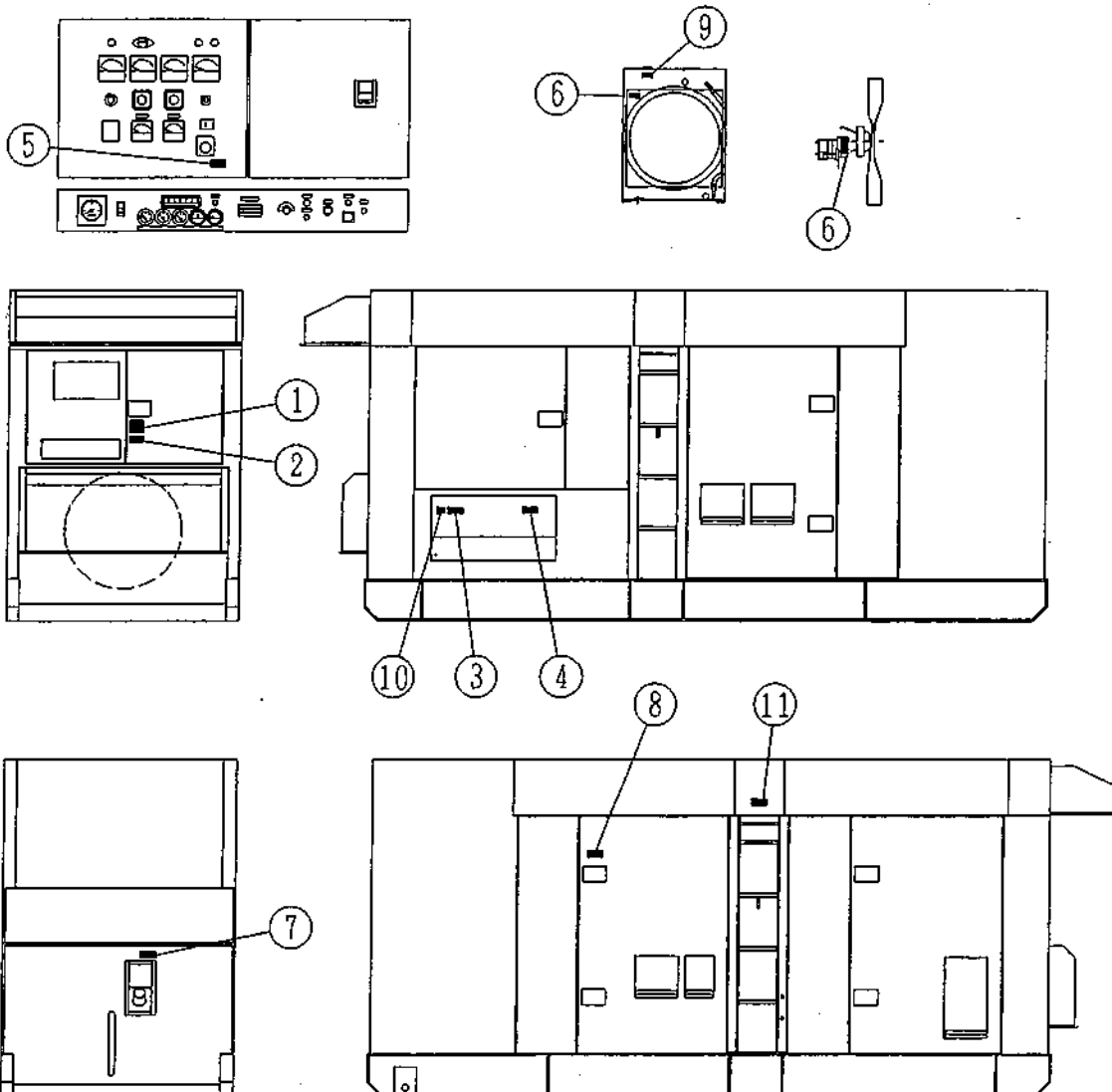

⚠ WARNING

ENGINE EXHAUST can kill.

■ Insufficient ventilation may lead to death due to lack of oxygen or poisoning by exhaust gases.

- * Do not use the machine in a place of poor ventilation or in a place where exhaust gases stay.
- * Do not use the machine indoors or in storehouse, tunnel, ship hold, tank, etc. of poor ventilation.
- * If it becomes necessary to use the machine in the above places, the exhaust pipe should be extended to a well ventilated place. In this case, use a ventilator to ensure proper ventilation.
- * Do not direct the exhaust outlet to nearby pedestrians and houses.

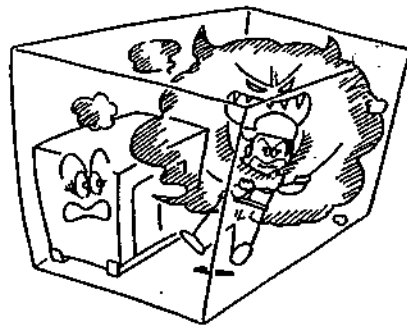
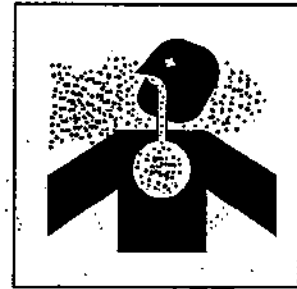

⚠ WARNING

ELECTRIC SHOCK can kill.

- Do not touch the output terminals during operation to prevent decrease due to electric shock.

* Never touch the output terminals during operation.

If your hands or the machine are wet, it will result in a death or serious injury.

* When a wiring work is required, be sure to turn OFF the circuit breaker and stop the machine.

(In the parallel operation, be sure to shut down the other machine.)

* Keep the output terminal cover closed and the terminal bolts tightened while the machine is running.

* A low voltage is generated even when the machine is in low speed idle operation.

Be sure to stop the machine completely.

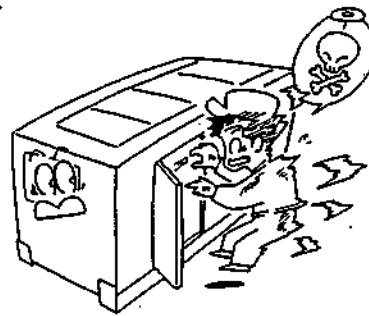

- Do not touch the electrical parts in the machine during operation, as it may lead to death due to electric shock.

* Always close the control panel and tighten the fixing bolts before operating the machine.

* Always close the side door and lock it before operating the machine.

* When opening the control panel for voltage selection, etc. , turn OFF the circuit breaker and stop the machine.

(In the parallel operation, be sure to shut down the other machine.)

⚠ WARNING

ELECTRIC SHOCK by leak can kill.

- Improper grounding may lead to death due to electric shock.

「 4-4. Grounding See p.32」

- * Be sure to execute the grounding of the machine and the load according to the local rule.



⚠ WARNING

MOVING PARTS can cause severe injury.

- Rotary unit which runs at a high speed is located in the machine.

(Note that it is very dangerous if you touch it.)

- * Be sure to close the door and lock it during operation.
- * When the door needs to be opened during operation, do not get your hands and head in the machine to prevent them from being caught in the machine which may lead to injury.
- * When making check or maintenance of the machine, be sure to stop the machine in advance.

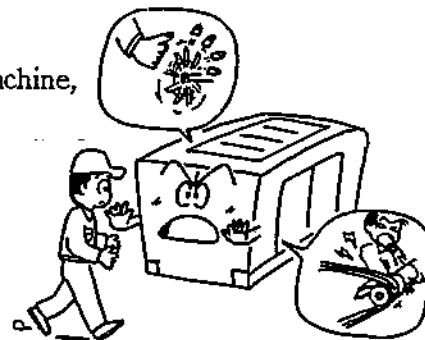
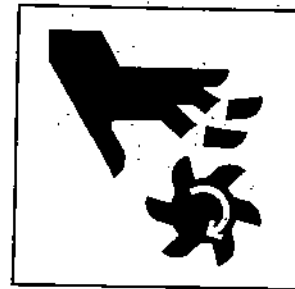

⚠ WARNING

DIESEL FUEL can cause fire or explosion.

- Fuel and oil are flammable. Incorrect handling results in danger of ignition or fire.
- * When fuel needs to be supplied to the machine, be sure to stop the engine. Refrain from smoking. Keep the machine away from fire.
- * Do not leave flammable objects (paper, wood chips, etc.) and hazardous objects (oil, powder, etc.) near the machine.
- * Wipe off spilt fuel and oil.

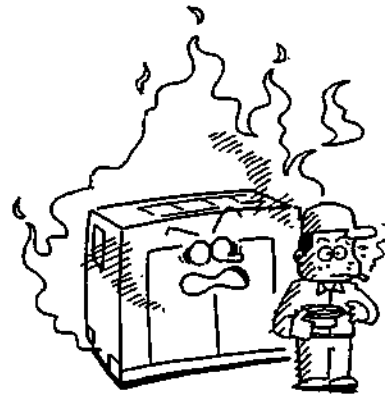

⚠ WARNING

HOT COOLANT can cause severe scalds.

- If the radiator cap is opened while the water temperature is high, steam or hot water will spout out.
- * During operation or immediately after stopping the machine, do not open the radiator cap while the water temperature is high.
- * When cooling water needs to be checked or supplied, wait until the engine is cooled (50 °C or less as measured with the water temperature gauge).

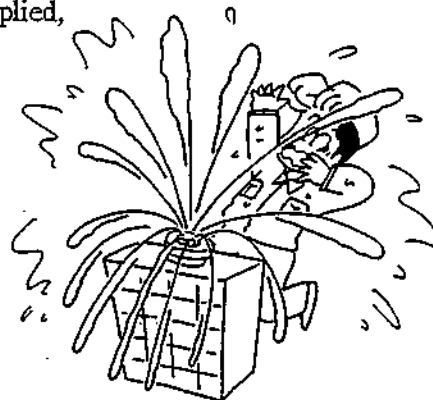
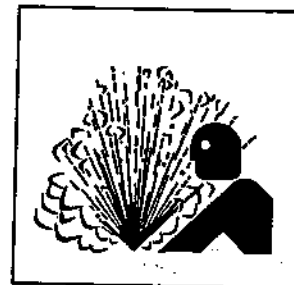

⚠ CAUTION

Stacking

- Improper stacking of machines may cause falling or dropping accidents.

When stacking other machines on this machine, be sure to observe the following points.

- * Check that the bonnet of the machine is free from damage and that the fixing bolts are not loosened and missing.
- * Put the machine horizontally on a solid foundation which withstands the weight of stacked machines.
- * Machines can be stacked up to 2 stages.
The weight and size of stacked machines should be less than those of this machine.
- * Using square timbers as shown right, put each machine making sure that the weight is even.

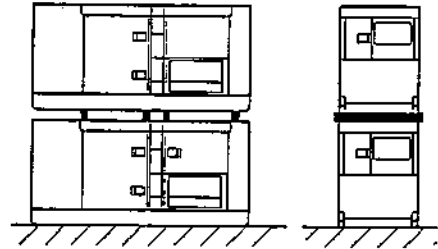

- Do not operate the machines in the state of stacking to prevent falling or dropping accidents.

⚠ CAUTION

HOT PARTS can burn skin.

- High temperature units are located in the machine.
(Note that these units are very dangerous if they are used incorrectly.)

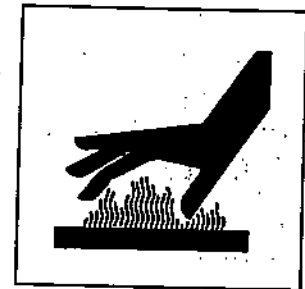

- * Be sure to close the door and lock it during operation.
- * If the door needs to be opened during operation, do not get your hands and head in the machine to prevent unexpected burns.
- * When making check or maintenance of the machine, be sure to stop the machine.
- * The bonnet is still hot even after the machine is stopped.

Be careful until the engine is completely cooled.

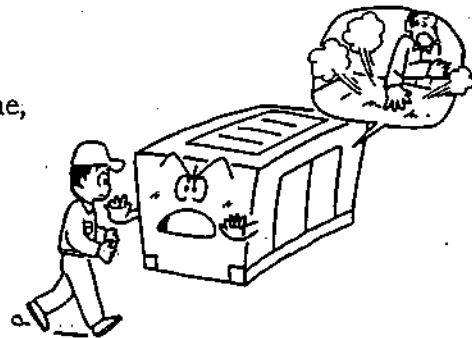

⚠ CAUTION

BATTERY

- Battery generates flammable gases.

Improper handling may lead to explosion or serious injury.

- * Battery should be charged in a well ventilated location. Otherwise, flammable gases are accumulated which may be ignited and exploded.
- * When connecting a booster cable, do not jumper the terminals (+ and -). Otherwise, the flammable gases generated from the battery may be ignited and exploded by sparks.
- * For maintenance of the machine, disconnect the ground cable on the ground side.

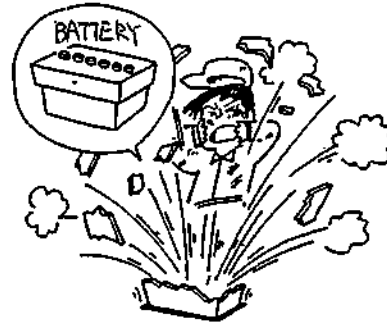
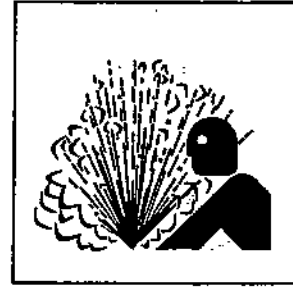

- The battery acid is dilute sulfuric acid. Improper handling will cause unexpected burns.

* When the battery acid gets on your clothes or skin, wash it out with a large volume of water immediately. If it gets in your eyes, wash with a large volume of water immediately and consult your doctor.

– In the worst case, it will put out your eyes.

- For checking or handling of the battery, be sure to stop the engine and turn OFF the battery switch in advance.

⚠ CAUTION

Muffler

- During operation or immediately after stop of the machine, touching to muffler may burn skin.

* Muffler is on the roof of the machine. After stop of the machine, do not go up the roof until the muffler is completely cooled.

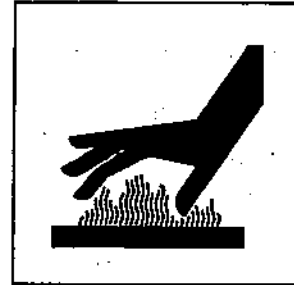

⚠ CAUTION

Operator

- Do not operate the machine, if operator is tired too much or drinks some alcohol or take some drugs.

* Otherwise, it may cause unexpected accidents or injury.

- During checking or maintenance, be sure to put on suitable clothes and protectors.

* Do not put on baggy clothes, necklace, etc., because they are easily caught by projections which may cause injuries.

⚠ CAUTION

Noise

- This machine generates large noise, if the door is open. Surrounding to large noise may cause hearing trouble.

* Close and lock the door during operation.
* If opening the door is necessary during operation, be sure to put on the ear protector.

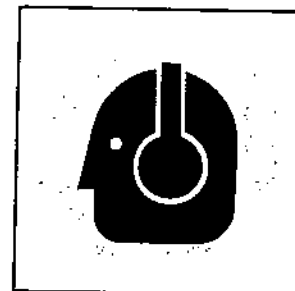

⚠ CAUTION

Connection to house wiring

- Before connecting this machine to any building's electrical system, a licensed electrician must install an isolation(transfer) switch.

* Serious injury or death may result without this transfer switch.

⚠ CAUTION

Transportation

- Do not lift the machine at the support hook or the ladder because it is not strong enough for lifting and may cause a falling accident.

* When lifting the machine, use the two hangers located at the roof center.

* Keep out under the lifted machine.

- Do not lift or do not transport the machine during operation, as it may cause damage to the fan or serious trouble.

* When loading the machine on the truck or the like, fix the machine firmly by support hooks on the both side.

The detail as machine size is referred to
「 12-1. Specifications See p. 79 」 and
「 12-2. Outline drawing See p.80 」 .

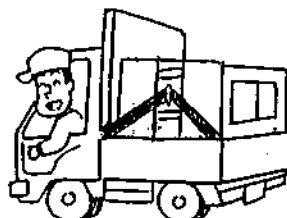
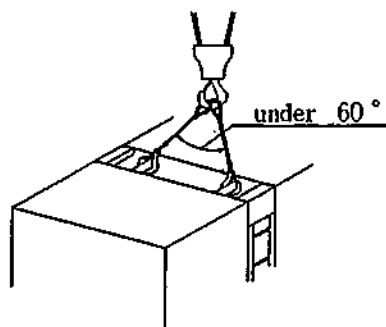

2. Construction

2-1 Outline and part names

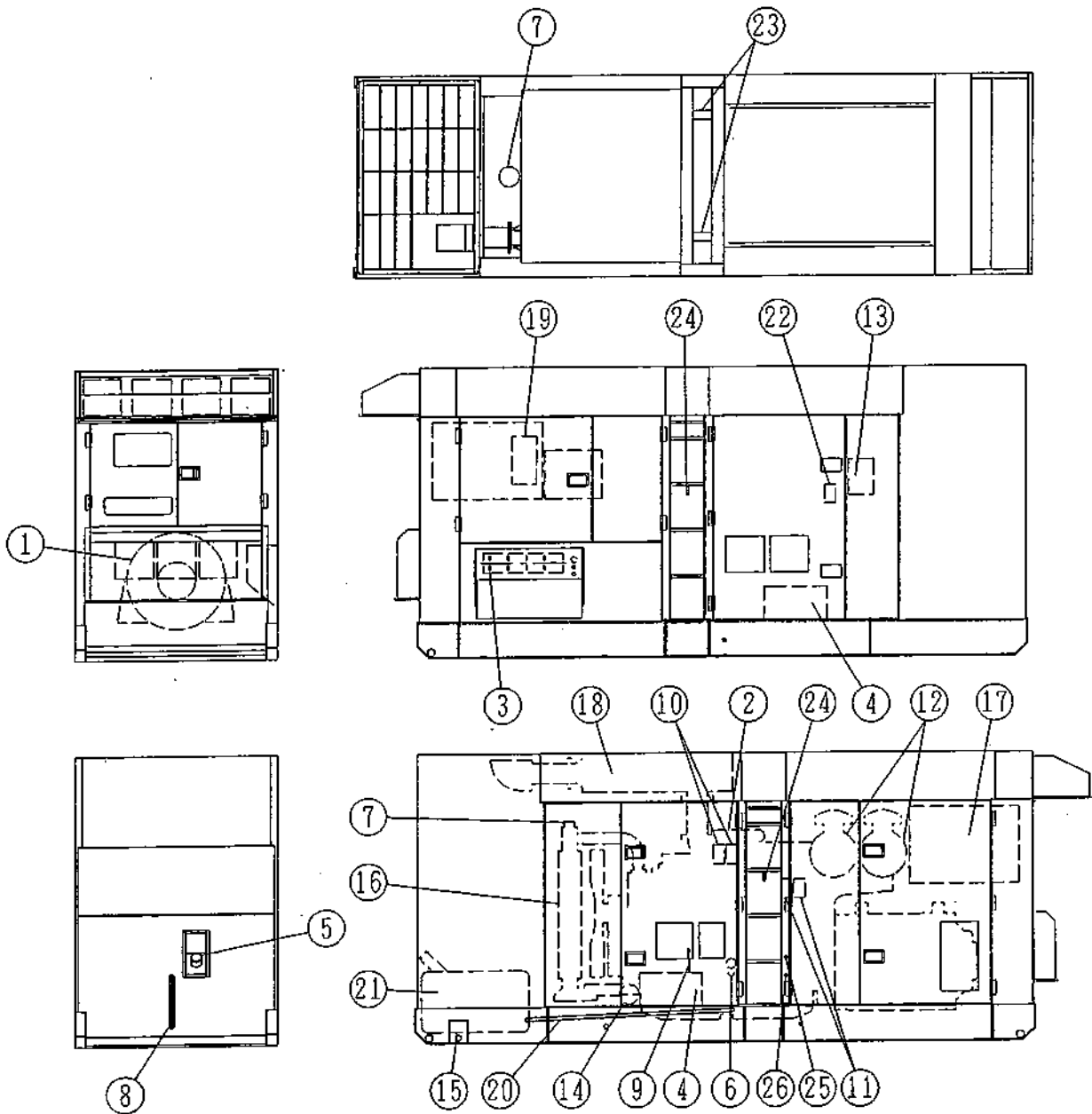

- 1 AC generator
- 2 diesel engine
- 3 output terminal
- 4 battery
- 5 fuel in
- 6 engine oil in
- 7 coolant in
- 8 fuel level gauge
- 9 dipstick

- 10 fuel filter
- 11 oil filter
- 12 air cleaner
- 13 coolant reserve tank
- 14 oil drain pump
- 15 fuel drain plug
- 16 radiator
- 17 control box
- 18 muffler

- 19 voltage change over board
- 20 breather pipe
- 21 fuel tank
- 22 corrosion resistor
- 23 hanger rod
- 24 support hook
- 25 fuel inlet
- 26 fuel outlet

2-2 Operating panel, control panel and part names

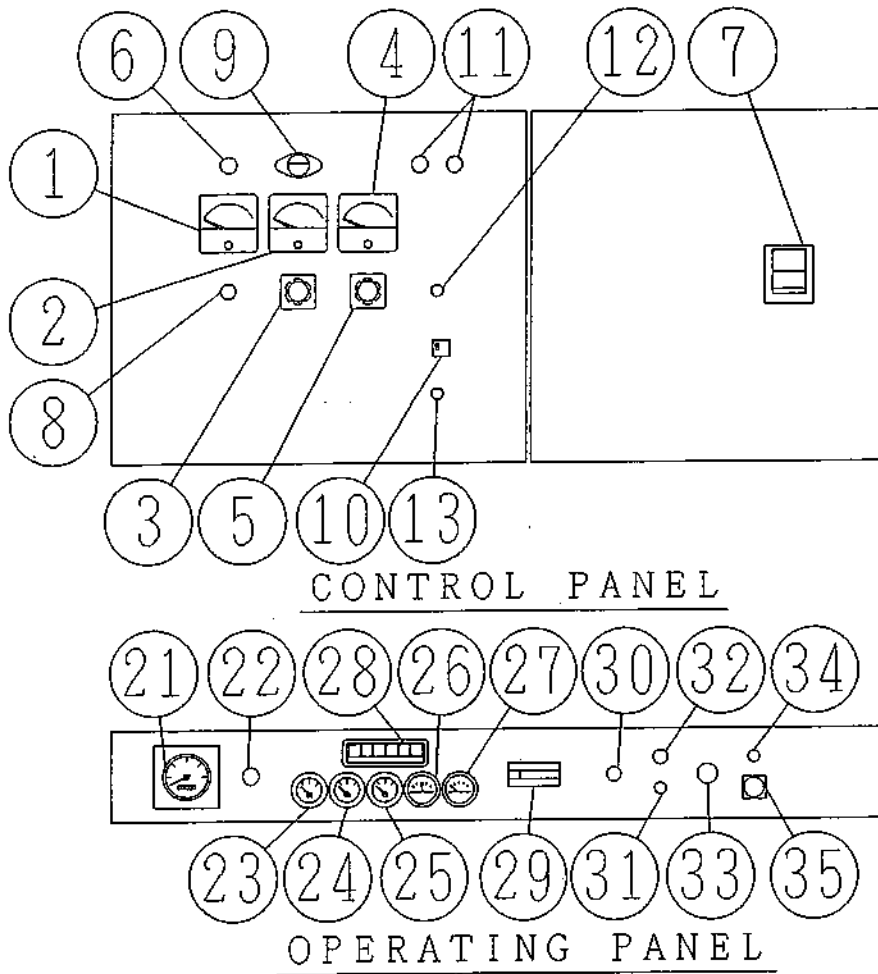

- | control panel | operating panel |
|---------------------------------------|-----------------------------|
| 1 frequency meter | 21 tachometer |
| 2 AC ammeter | 22 throttle lever |
| 3 ammeter change-over switch | 23 oil pressure gauge |
| 4 AC voltmeter | 24 oil temperature gauge |
| 5 voltmeter change-over switch | 25 water temperature gauge |
| 6 pilot lamp | 26 charging ammeter |
| 7 circuit breaker | 27 fuel gauge |
| 8 voltage regulator | 28 warning lamp unit |
| 9 panel light | 29 battery switch |
| 10 panel light switch | 30 starter switch |
| 11 synchronizing lamp | 31 heater switch |
| 12 single-parallel change-over switch | 32 preheat lamp |
| 13 frequency change-over switch | 33 emergency stop button |
| | 34 running caution lamp |
| | 35 speed chang- over switch |

2-3 Meters

Engine indicators

(1) Tachometer (0-3000rpm)

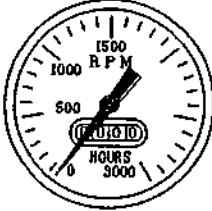

This meter indicates the number of revolutions (per minute) of the engine.

It indicates 1500rpm at 50Hz or 1800rpm at 60Hz.

(2) Hour meter

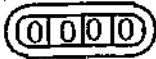

This meter indicates the total running time of the engine. This meter is built in the tachometer.

The hour meter has been set for use at 1500rpm. Accordingly, when the machine is used at 1800rpm, it indicates the total time approximately 20% more than the actual operation time.

(3) Water temperature gauge



This is normal when it indicates 75 to 95 °C during operation.

[Note] If it indicates higher values, turn OFF the load and set the machine in cooling operation by setting the speed change-over switch to "LOW" position, and until the temperature lowers.

(4) Oil pressure gauge



This is normal when it indicates 3 to \times 100kPa during operation.

If the engine is cool, it may indicate higher values at the time of startup. Put the engine in warming up operation and wait until oil pressure becomes normal.

(5) Charging ammeter

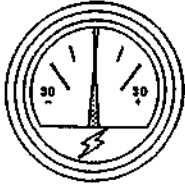

This meter indicates the current supplied by the alternator to batteries.

It is normal when it indicates the range of 0 or +.

(6) Fuel level gauge

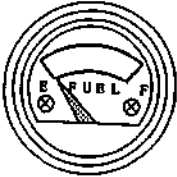

This meter indicates the fuel level in the fuel tank.

(7) Oil temperature gauge



This meter indicates the oil temperature of the engine oil.

It is normal when it indicates 70 to 120 °C during the operation.

Generator indicators

(1) Frequency meter

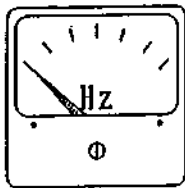

This meter indicates frequency of the output voltage.

Make sure that it indicates 50Hz or 60Hz during operation.

(2) AC ammeter

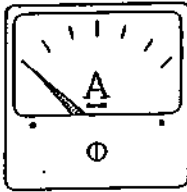

AC Ammeter

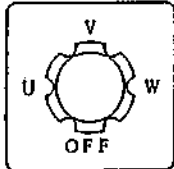

Ammeter change-over switch

This meter indicates AC current flowing into the connected load. Make sure that it is always pointing below the rated current.

The current of each phase can be checked using the ammeter change-over switch.

(3) AC voltmeter

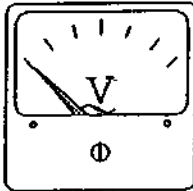

AC Voltmeter

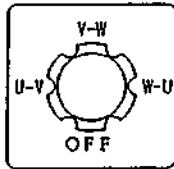

Voltmeter change-over switch

This meter indicates AC output voltage. Make sure that it indicates rated voltage.

Line-to-line voltages can be checked using the voltmeter change-over switch.

Indication/alarm lamp

(1) Preheat lamp

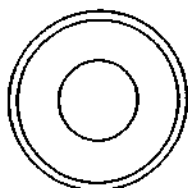

This lamp is for starting in the cold weather. Pull the heater switch, and about 80 seconds later the lamp will turn off to indicate a completion of preheating.

(2) Running caution lamp



This lamp goes on during low speed operation.

(3) Warning lamp nit

This monitor indicates the following failures, if any one of them occurs.

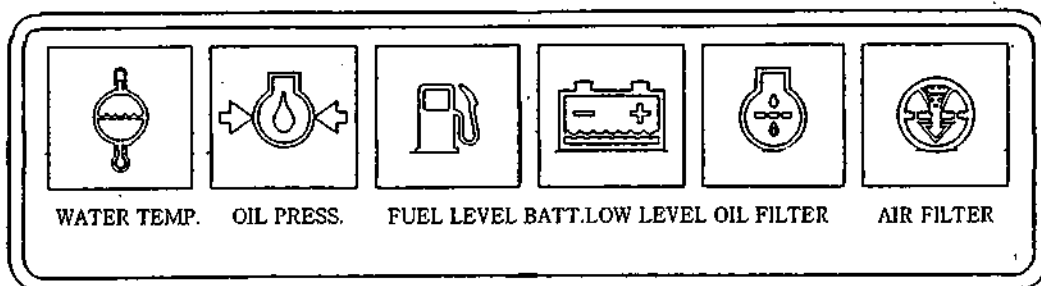

① High jacket water temperature (WATER TEMP)



This lamp goes on when the water temperature rises abnormally. If the lamp goes on during operation, the emergency stop device immediately operates to shut down the engine automatically.

「 5-1.(2) Check on engine cooling water See p.36 」

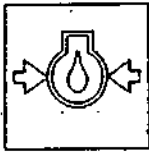

② Oil pressure failure (OIL PRESS)

If the machine is in normal operation, this lamp stays off. When the starter switch is turned to "RUN" position to start the engine, the lamp goes on, and when the oil pressure rises after startup, it goes off. If this lamp goes on during operation, the emergency stop device immediately operates to shutdown the engine automatically.

After stop of the engine, the lamp stays on unless the starter switch is turned to "STOP" position.

「 5-1.(1) Checking on engine oil See p.35 」

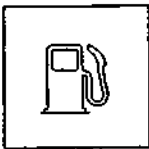

③ Fuel level failure (FUEL LEVEL)

When fuel is running low, this lamp goes on, and it should be supplied at the tank.

「 5-1.(4) Check on fuel See p.37 」

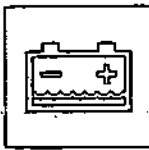

④ Battery acid level failure (BATT LOW LEVEL)

When battery acid is running low, this lamp goes on, and distilled water should be supplied to the battery.

「 5-1.(5) Check on battery acid See p.38 」



⑤ Oil filter blinding (OIL FILTER)

When the oil filter is blinded, this lamp goes on. Indicating that the oil filter should be immediately replaced and also replace the engine oil concurrently.

「 9-2.(1) Replacement of engine oil See p.64 」

「 9-2.(2) Replacement of engine oil filter element See p.65 」



⑥ Air filter blinding (AIR FILTER)

When the air element is blinded, this lamp goes on. Indicating that the element should be immediately cleaned or replaced.

「 9-2.(3) Cleaning of air cleaner element See p.66 」

「 9-4.(2) Replacement of air cleaner element See p.71 」

2-4 Use of switches and controllers

Switches

(1) Battery switch

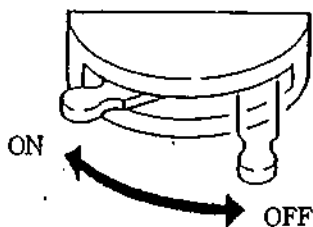

This switch should be set in the "ON" position during operation. And after stop the engine, this switch should be set in the "OFF" position.

[Note] Do not turn this switch to "OFF" position during operation. Otherwise, the engine may not be able to be stopped by normal operation, or it may cause damage to the electric equipment.

(2) Starter switch

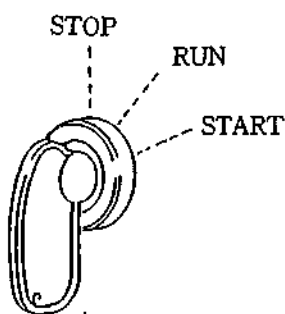

Functions:

① STOP

This switch should be set in this position unless the machine is in operation. The key can be inserted or pulled out in this position.

② RUN

This switch should be set in this position when the machine is in operation.

③ START

This is the position to start the engine. When your hand is released from the key after starting, it is automatically set in the position of "RUN".

(3) Speed change-over switch

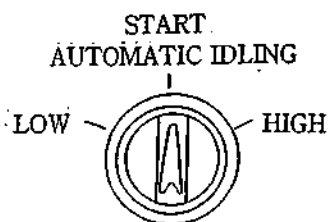

Functions:

① START / AUTOMATIC IDLING

When the engine is started with the speed change-over switch set at this position, the engine idles for about 20 seconds and then automatically changes over to high speed operation.

When starting the engine, set the switch in this position.

② LOW

When the switch is turned to this position, the engine continues to idle. When stop of the engine, turn the speed change-over switch to this position and put the machine in cooling operation for a few minutes before turn the starter switch to "OFF" position.

③ HIGH

Setting the switch to this position releases the automatic idling function, allowing the engine to be run at the speed set by the throttle lever.

(4) Heater switch

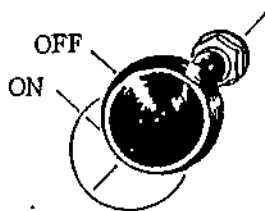

When start up the engine at cold weather, this switch is used.

「 5-3. Starting in the cold weather See p.43 」

(5) Emergency stop button



This is a push button to stop the engine urgently on emergency case.

[Note]

Do not push the button without emergency case.

(6) Circuit breaker

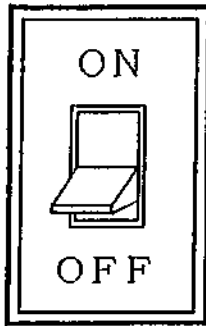

This is a main switch to supply power to a load.

When the load is shorted or in the state of overload, it trips to protect the generator against trouble.

[Note]

Do not use this circuit breaker to turn ON/OFF the load, to prevent damage to the circuit breaker.

When it trips with overcurrent, the handle of the breaker stops between ON and OFF positions. This is what is called the trip condition.

In this case, push the handle down to the OFF position to reset it, or else, it cannot be set in ON position.

(7) Single-parallel change-over switch

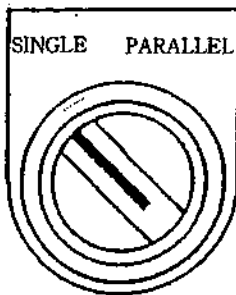

In case of operation of single unit, turn this switch to the side of "SINGLE". In case of parallel operation, turn the switch to the side of "PARALLEL". In the parallel mode, the synchronizing lamp and the cross current compensation circuit function to enable the parallel operation. If the switch is in the parallel mode at the time of single operation, output voltage will drop according to load size.

While, if the switch is in the single mode at the time of parallel operation, cross current will occur between the generators to trip the circuit breaker.

(8) Frequency change-over switch

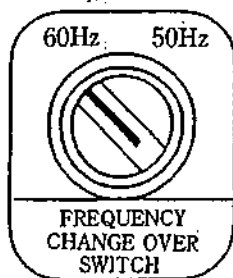

This is for switching the frequency from/to 50Hz or to/from 60Hz.

(9) Panel light switch

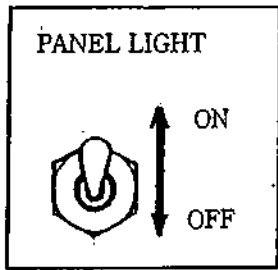

This is the switch to turn on the panel light.

Voltage regulator and throttle lever

(1) Voltage regulator

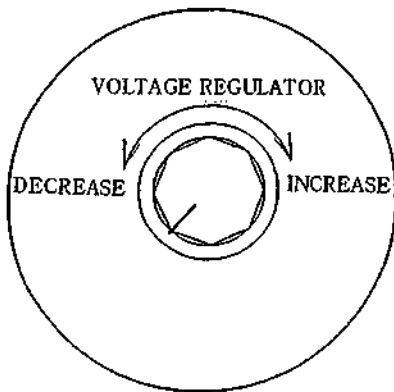

This regulator is used to control the output voltage. Turn the regulator to clockwise to increase the voltage and counter clockwise to decrease it.

Adjust the voltage to the rated voltage with this regulator.

(2) Throttle lever

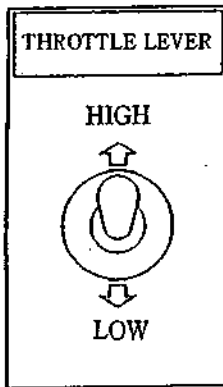

Turn the handle toward the "HIGH" side to increase the speed and toward the "LOW" side to decrease it.

Overcurrent relay

RESET BUTTON

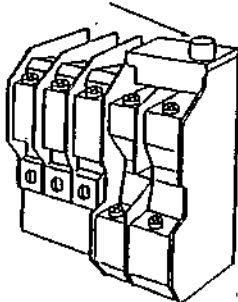

This relay is used to trip the circuit breaker when overcurrent flows into the circuit.

If the circuit breaker trips and cannot be closed, stop the engine and open the control panel. Then press the reset button.

[Note]

Do not change the set value unnecessarily.

2-5 Electronic governor controller

This machine is equipped with the electronic governor.

In the control panel, there are the controller, switches, trimmer, etc., for controlling the governor. This paragraph gives the operating procedure for the controls. Do not operate the controller under no necessity since it is for the adjustment at factory.

(1) Droop curve trimmer (VR2)

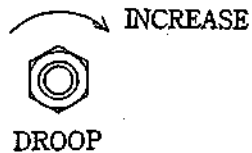

This is the trimmer to adjust the droop characteristics of the engine rpm. By this, the speed regulation is adjustable in the 3 to 5 % range.

(2) Idle adjust trimmer



This is the trimmer to adjust the slow idling rpm of the engine. By this, the idling speed is adjustable in the range of 750 to 900 rpm.

(3) Trouble indicator lamps (LE1 and LE2)

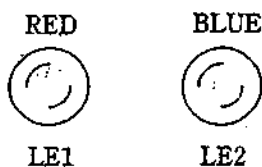

These are the indicator lamps for trouble shooting for engine.

Upon turning the starter switch to RUN, both of the two lamps turn on for approximate half second at first.

If there is no trouble, the red lamp (LE1) only keeps on. If there is a trouble, the two lamps show the section in trouble by the combination of lighting and flickering.

(4) Reset button (PB1)



This is the reset button for the trouble indicator lamps. The indicator lamps will keep on showing the trouble even after it is corrected and engine is started again. To cancel such condition and recover the normal indication, press this push button for five seconds.

3. Transportation and installation

3-1 Transportation of machine

CAUTION

Transportation

- Do not lift the machine at the support hook or the ladder because it is not strong enough for lifting and may cause a falling accident.

* When lifting the machine, use two the hangers located at the roof center.

* Keep out under the lifted machine.

- Do not lift or do not transport the machine during operation, as it may cause damage to the fan or serious trouble.

* When loading the machine on the truck or the like, fix the machine firmly by support hooks on the both side.

The detail as machine size is referred to

「 12-1. Specifications See p.79 」 and

「 12-2. Outline drawing See p.80 」 .

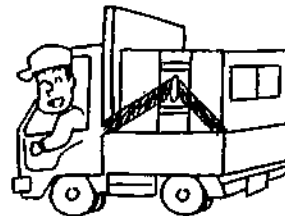
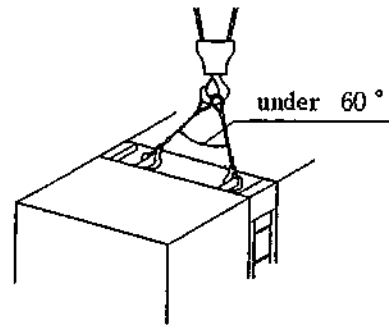

3-2 Installation of machine

⚠ WARNING

ENGINE EXHAUST can kill.

- Insufficient ventilation may lead to death due to lack of oxygen or poisoning by exhaust gases.
- * Do not use the machine in a place of poor ventilation or in a place where exhaust gases stays.
- * Do not use the machine indoors or in storehouse, tunnel, ship hold, tank, etc. of poor ventilation.
- * If it becomes necessary to use the machine in the above places, the exhaust pipe should be extended to a well ventilated place. In this case, use a ventilator to ensure proper ventilation.
- * Do not direct the exhaust outlet to nearby pedestrians and houses.

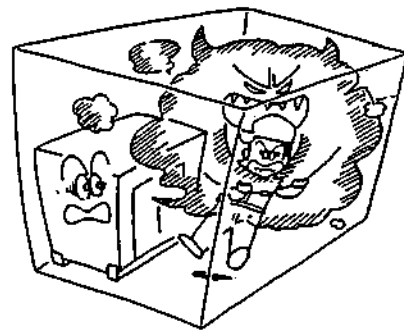
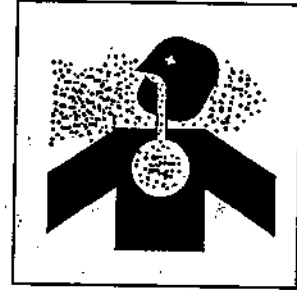

[Note] vibration:

The engine, running, generates vibration during operation of the machine.

When installing the machine, be sure to observe the following points.

- ① Install the machine horizontally on a solid foundation.
Operation on an uneven place will generate unusual vibration.
- ② The machine should be installed on a substantial base to prevent claims from nearby living people. For details of the vibration level of the machine and foundation work, contact distributor or our office.

[Note] noise:

The engine is running during operation of the machine.

If the door is open, much noise will be generated. But some noise will stay, when door is closed.

When installing the machine, be sure to observe the following points.

- * Close and lock the door after installation.
- * We recommend to execute the measure for sound level to prevent claims from nearby living people.

[Note]

This machine is designed for the operation at a level solid foundation or ground. To avoid a trouble, do not operate this machine in the other conditions.

Installation procedure

- * Install the machine horizontally on a solid foundation.
- * Provide a space of more than about 1m at the side of the control panel and fuel feed port to ensure correct operation and supply.
- * Provide a space of more than about 1.2m on the left and right sides for check of the engine, oil supply and cable connection work.
- * A sufficient space is required at the top of the machine to allow hot air (exhaust air) from the radiator and exhaust gases to be discharged and to supply water to the radiator.
- * When the machine is operated in a place with much dust or salt, careful maintenance is required to prevent clogging or damage to the radiator or poor insulation of electric parts.

Indoor installation

- * Exhaust gases should be discharged outdoors using an exhaust pipe.
- * Exhaust air should also be discharged outdoors using a duct or the like.
- * Insufficient indoor ventilation will raise the (indoor) temperature and affects the performance of the machine.
- * For details of required volume of ventilation, contact distributor or our office.

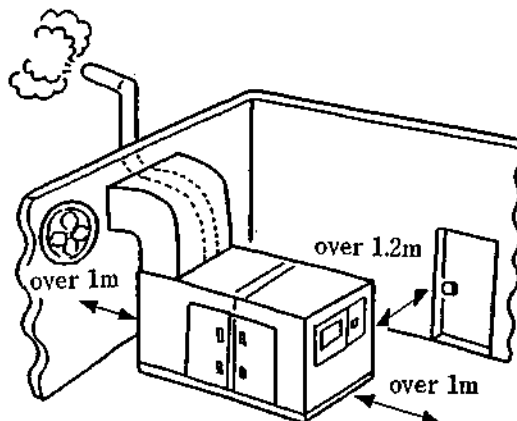

4. Connecting the load

4-1 Method for selecting output voltage

WARNING

ELECTRIC SHOCK can kill.

- Do not touch the circuit inside the machine during operation to prevent decrease due to electric shock.

* When open the control panel or the like for changing the output voltage, turn OFF the breaker and stop the machine in advance.

In the parallel operation, be sure to shut down the other machine.

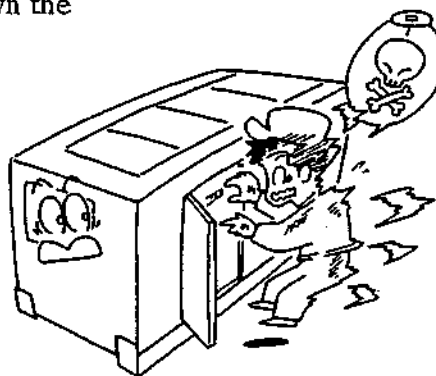

The machine is designed with double voltage specification, which allows the output voltage of 200 V class or 400 V class to be selected with the voltage change-over plates.

Method for selecting output voltage

The machine is shipped from the plant with its output voltage normally set at 200/220V unless otherwise specified.

Therefore, select the output voltage required for work in accordance with the procedure described following :

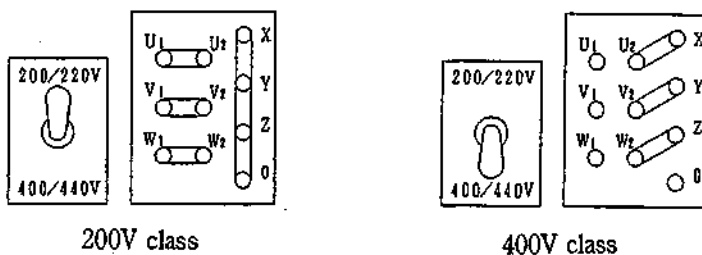

- ① Never forget to confirm the engine is in a stop.
- ② Open th right side door and remove the protection cover of the control panel. The voltage change—over board is located on a right side of the control box.
- ③ Select the output voltage by setting the change—over plates as shown in the previous page. Setting for 400 V or the like will make a surplus. To prevent them from missing, pile and tighten the plates.
- ④ Turn the change—over switch on the voltage change—over board to the voltage you require.
- ⑤ Mount the protection cover and close and lock the side door.

[Note] Incorrect reconnection of the change—over plates may cause a burning accident in the generator. For reconnection, be sure to tighten the plates to prevent the burning accident.

Be sure to mount the protection cover before starting engine again.

4 - 2 Cables to be used

Selection of cables:

Use cables having sufficient size in consideration of the allowable current of the cables and the distance between the machine and the load.

If the load current exceeds the allowable current of cables, the cable may be damaged by overheat. Also, if the cables are too small in size for the length, the input voltage of the load drops which lowers the working efficiency or causes failure in operation.

Select the length and size of cable so that the voltage drop "e" obtained by the following equation is within 5% of the rated voltage.

* Equation to obtain 3-phase, 3-wire system voltage drop "e" from the length and size of cable and operating current is as follows.

$$e = \frac{1}{58} \times \frac{L}{S} \times I \times \sqrt{3}$$

where e: voltage drop (V) L: length (m)
S: cable thickness(mm²) I: load current (A)

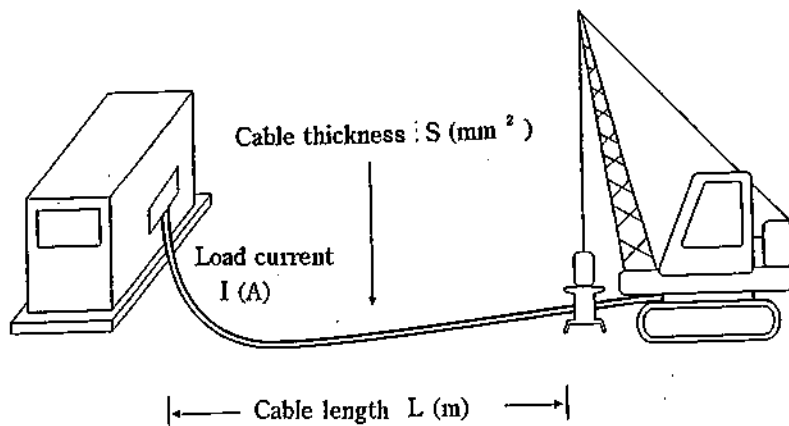

4-3 Connecting the load

ELECTRIC SHOCK can kill.

- Do not touch the output terminals during operation to prevent decrease due to electric shock.
- * When a wiring work is required, be sure to turn OFF the circuit breaker and stop the machine.
- * When operating the engine, close the output terminal cover. Tighten the fixing bolts before operating the machine.

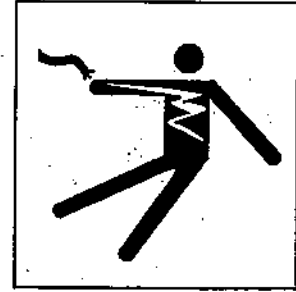

- Do not use damaged cables to prevent electric shock. Insufficient tightening of bolts will generate heat at connections which may result in fire accidents.
- * When connecting, make sure the connecting cables are normal and connected firmly to the output terminals.

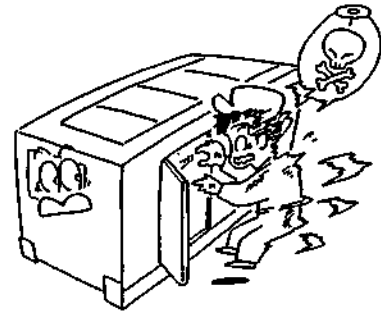

⚠ CAUTION

Connection to house wiring

- Before connecting this machine to any building's electrical system, a licensed electrician must install an isolation(transfer) switch.
- * Serious injury or death may result without this transfer switch.

(1) Fastening the output terminal

Connect and tighten the output terminals for the 3-phase/4-wire system, as shown in the figure below.

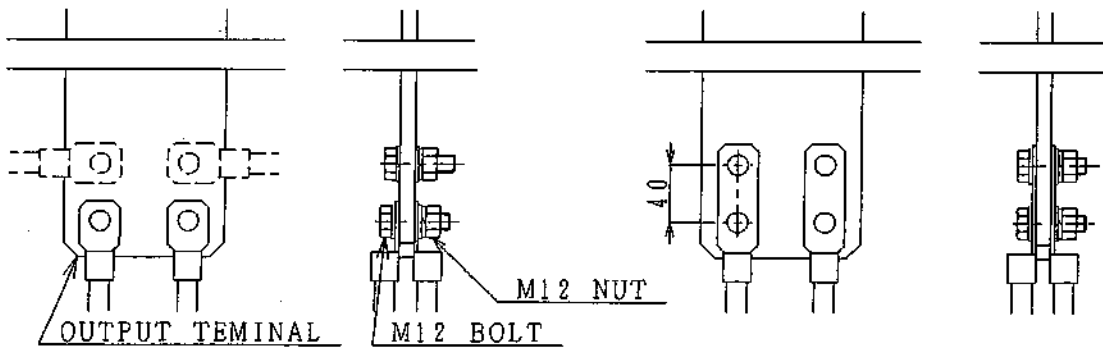

In case of connecting 2 cables or more, follow the above figure. The above figure indicates a sample connection of one of the 3-phase. Apply the connecting method also to other phases.

[Note] In connecting a cable, be sure to tighten the connection completely with a wrench. Loose connection can cause a burning accident.

Be sure to fit a pressure terminal of adequate size with the cable. Never connect the cable without a pressure terminal, since it may cause an abnormal heating.

(2) Connecting three phase output terminal

Connect the load to the output terminal after confirmation of load phase and voltage.

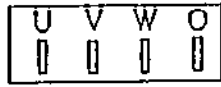

Use U/V/W for three phase load

200/220V or 400/440V

(190V) (380V)

{415V}

[240V] [480V]

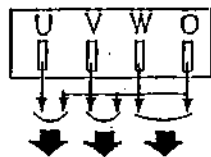
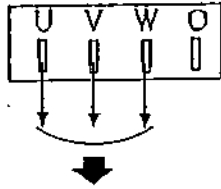

Use O/U,O/V,O/W for single phase load

115/127V or 231/254V

(110V) (219V)

{240V}

[139V] [277V]

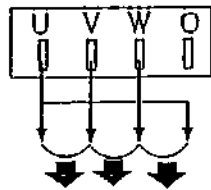

Use U/V,V/W,W/U for single phase load

200/220V or 400/440V

(190V) (380V)

{415V}

[240V] [480V]

(3) Precaution in load connection

- ① Be sure to provide a switch for turning the load ON and OFF between the output terminal block and the load.

Note that the use of the breaker of the machine for turning the load ON and OFF may result in breaker failure.

- ② In connecting the load, be sure to stop the engine and turn OFF the breakers on the control panel and the out put terminal block.

- ③ Don't contact the connecting cable to the output terminal of other phase on the output terminal block.

- ④ When the load connection is finished, close the cover of output terminal and tighten by the bolts.

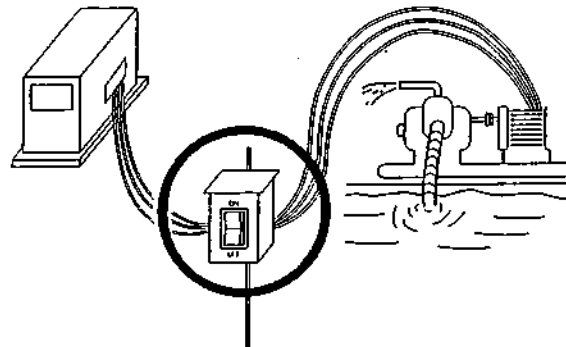

4-4 Grounding

WARNING

ELECTRIC SHOCK by leak can kill.

- Improper grounding may lead to death due to electric shock.

* Be sure to execute the grounding of the machine and the load according to the local rule.



Grounding

Execute the grounding certainly to prevent the electric shock by leak.

(1) Case grounding of the machine

Use the grounding wire which sectional area conforms to the local rule.

Provide the grounding rod to satisfy the grounding resistance which conforms to the local rule.

(2) Case grounding of the load

Execute the grounding for the load similarly.

Provide the grounding rod to satisfy the grounding resistance which conforms to the local rule.

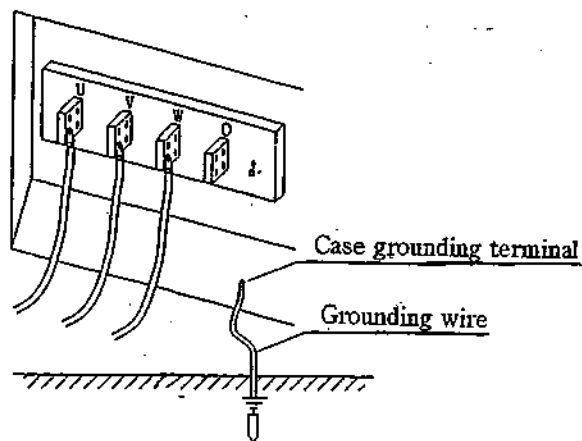

(3) Precaution in grounding

- ① Select a shady and highly moist place, and bury the grounding rod in such way that its top end is completely hidden in the ground.
- ② If burying the grounding rod on the place that many pedestrians walk on, clamp the lead wire to prevent catching on it.
- ③ If the lead wire is not long enough for the connection, connect it as directed below:
 - (1) Connect the lead wire and the extension wire by soldering or sleeve coupling securely and apply insulating tape to the connection.
 - (2) Do not bury the connection in the ground.
- ④ Avoid the places within 2m of lightning conductor grounding location for burying of grounding rod.
- ⑤ Do not use a telephone set grounding conductor.

5. Operation

— From pre-start check to shut down —

Be sure to check the machine prior to starting.

- 1.. Pre-start check : Check oil, cooling water, fuel and so on.
- 2.. Periodical check: Check each part of the machine according to operating time.
- 3.. Startup: Check the surroundings of the machine for safe operation.

Use a sign before startup.

- 4.. Operation:  In the machine there are moving parts, high temperature parts and high voltage parts. Before operating, close the door and lock the side door for safe operation and for prevention of noise.

[Note] If the warning lamp lights, stop the engine and check the cause of it.

[Note] Check for leaks of oil, water, exhaust gases, and for unusual noise.

- 5.. Shut down

5-1 Checking prior to operation

WARNING

MOVING PARTS can cause severe injury.

- Rotary unit which runs at a high speed is located in the machine.

(Note that it is very dangerous if you touch it.)

- * Be sure to close the door and lock it during operation.
- * When making check or maintenance of the machine, be sure to stop the machine in advance.

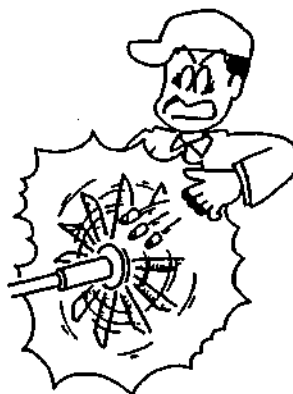

- To prevent unexpected trouble, be sure to check the following points.

- (1) Check on engine oil (lubricating oil)
- (2) Check on engine cooling water
- (3) Checking on fan belt
- (4) Checking on fuel
- (5) Checking on battery acid
- (6) Checking on grounding for electric shock protection
- (7) Checking for leakage of oil and water
- (8) Checking for loose parts
- (9) Removal of foreign objects in machine

Inspection:

- (1) Checking on engine oil

(Read the instruction manual for the engine furnished separately.)

- ① Checking the level of engine oil by the dipstick. Make sure the oil level is always between H and L.
- ② When it is below the low limit, supply oil immediately.
- ③ At the same time, check condition of oil by the dipstick.

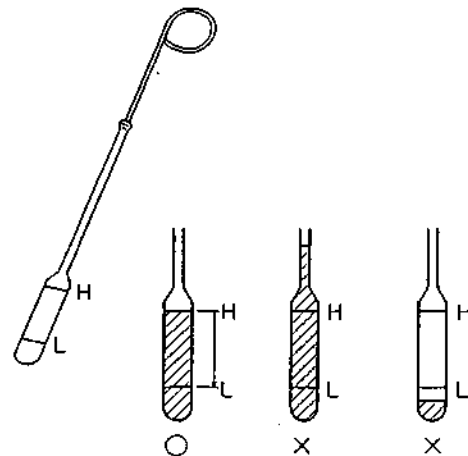

[Note]

Oil is consumed gradually during operation. When the machine is to be used continuously for a long time, be careful with lack of oil.

Handling of the machine equipped with an automatic oiler refers to 「13-1 Automatic Oiler See p.83」.

(2) Check on engine cooling water

(Read the instruction manual for the engine furnished separately.)

⚠ WARNING

HOT COOLANT can cause severe scalds.

■ If the radiator cap is opened while the water temperature is high, steam or hot water will spout out.

* During operation or immediately after stopping the machine, do not open the radiator cap while the water temperature is high.

* When cooling water needs to be checked or supplied, wait until the engine is cooled (50 °C or less as measured with the water temperature gauge).

- ① Check (to see) that cooling water in the reserve tank is within the range of FULL-LOW.
- ② When it is below the low limit, supply (additional) water immediately.
- ③ Normally, only the water level of the reserve tank needs to be checked.

But, the radiator cap should be opened once a week to check that water is full in the radiator.

[Note]

When closing the radiator cap after water level is checked or water is supplied, turn the cap fully clockwise so that it can be firmly tightened.

Otherwise, cooling water is evaporated which results in serious damage to the engine.

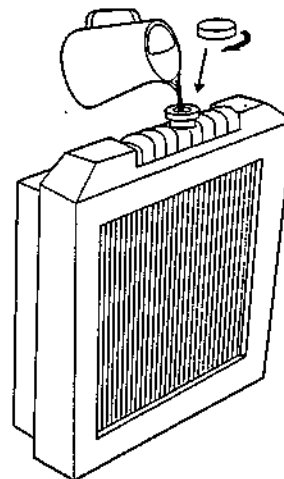
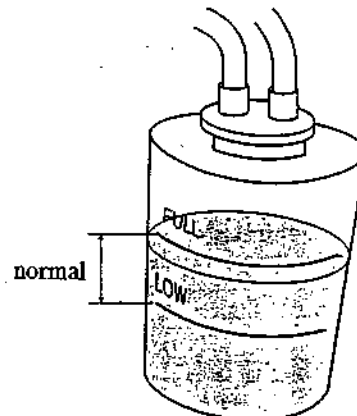
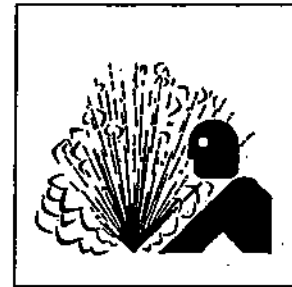

(3) Check on fan belt

(Read the instruction manual for the engine furnished separately.)

- ① Check the belt for tension and elongation.
Also, check it for damage. Replace if necessary.
- ② For adjustment or replacement of the belt, refer to the instruction manual for the engine.

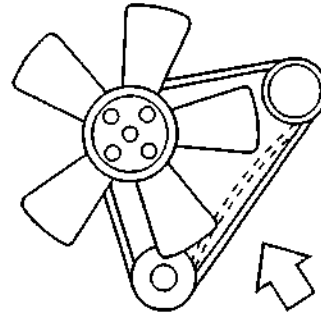

Press (about 6kg) the position shown by arrow mark (middle of belt) with your thumb. The bend should be within the range of 10–15mm.

(4) Check on fuel

- ① Be sure to check the quantity of fuel prior to operation to prevent lack of fuel during operation.
- ② Loosen the drain plug of the fuel tank from time to time, and remove sediments and water at the bottom of the tank.

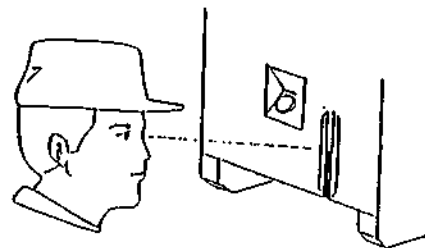

(5) Check on battery acid

⚠ CAUTION

BATTERY

■ The battery acid is dilute sulfuric acid. Improper handling will cause unexpected burns.

* When the battery acid gets on your clothes or skin, wash it out with a large volume of water immediately. If it gets in your eyes, wash with a large volume of water immediately and consult your doctor.

– In the worst case, it will put out your eyes.

Remove the battery acid plug(cap) and check the liquid level (10–12mm above the electrodes). Supply distilled water if necessary.

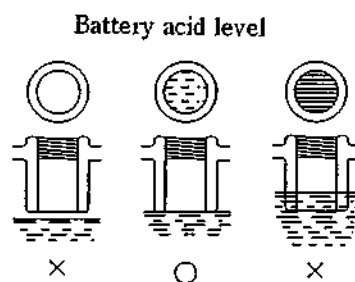
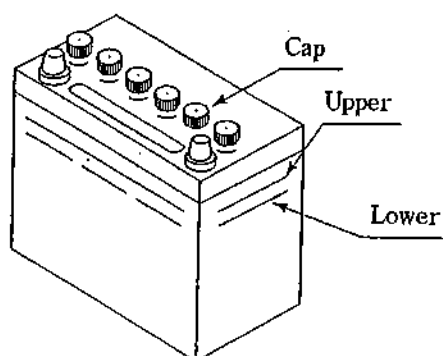

(6) Check grounding for electric shock protection

Make sure that the case grounding of the machine and the load are certainly.

「 4-4. Grounding See p.32 」

Do not ground directly 「 O 」 terminal.

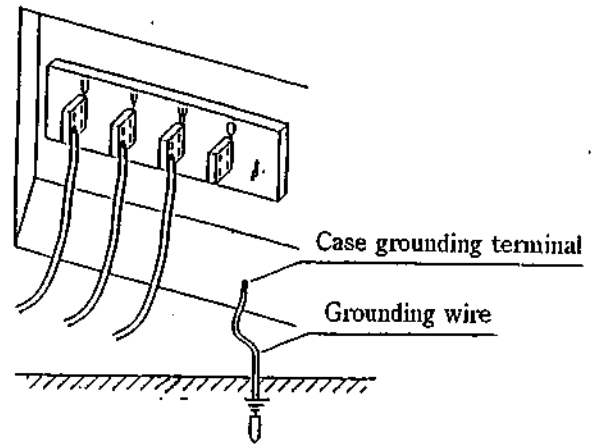

(7) Check for leak of water and oil

Check the machine for the trace of leak of oil or water. If a leak is found, check the location of leak and stop it. When the leak cannot be stopped, contact our service factory.

(8) Check for loose parts

Check for loose bolts and nuts. Loose parts should be tightened firmly. Particularly, make check on the fitting of air cleaner, muffler, turbo-charger, etc. , disconnection of electric wiring, short-circuit and loose terminals.

(9) Removal of foreign objects in machine

- * Check that tools and cleaning cloth are not left in the machine. Remove if necessary.
- * Check the surroundings of the muffler and engine for presence of dust and flammable objects. Remove if necessary.
- * Check that the cooling air inlet and the cooling air outlet of the machine are not clogged with dust or other objects. Remove if necessary.

5-2 Start up

This machine is equipped with automatic idling device. This device automates the idling of the engine for its warming-up after start up. Following is flow of start up.

When start up the machine cold weather, refer to 「5-3. Starting in the cold weather See p.43」

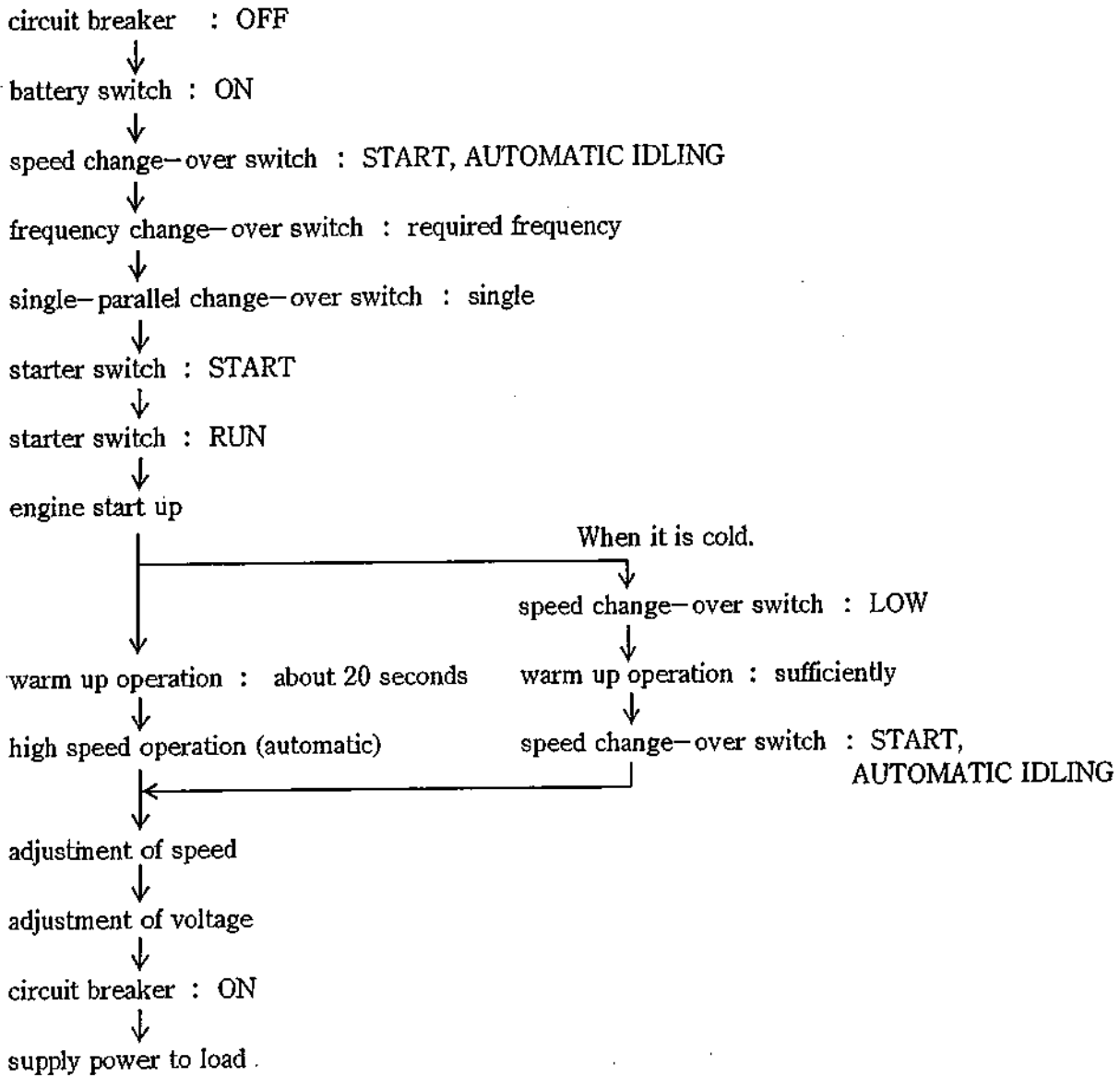

⚠ CAUTION

* Never start the engine when the circuit breakers on the generator and load sides are on. Immediate power feeding can cause an electrical shock accident or a load trouble.

Startup procedure: (Refer to 「 5-3. Starting in the cold weather See p.43 」)

- (1) See both the circuit breakers on the generator side and load side are all OFF.



- (2) Turn on the battery switch .

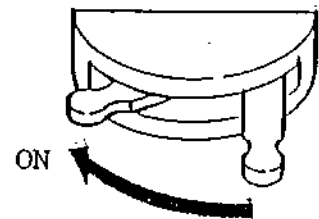

- (3) Turn the speed change-over switch on the control panel to the position of "START / AUTOMATIC IDLING".



- (4) Turn the frequency change-over switch to either 50Hz or 60Hz.

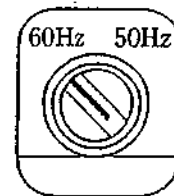

- (5) Turn the single-parallel change-over switch to single side.

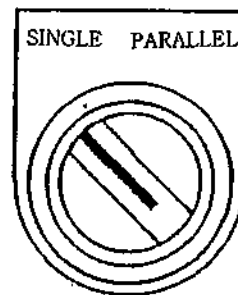

- (6) Turn fully the starter switch up to "START".

Immediately after engine starts up, release the starter key, and it comes to the "RUN" position automatically. For starting engine again immediately after shut down, once turn the switch to the "STOP" position or once turn off the battery switch, because the protective switch can be on and make it impossible to restart.

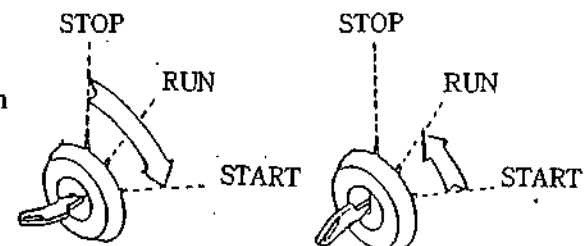

(7) Allow engine to run for warming up for a while. See all the alarm lamps are all off after starting engine. Soon after the engine starts up, it comes in idling automatically and the running caution lamp turns on. After about 20seconds, engine speed increases automatically to the high speed as set by the throttle lever.

[Note]

In the cold weather, turn the speed change-over switch to the position of "LOW" for warming up for longer time.

If the high speed run is required sooner and the engine is warm enough due to former running, turn the speed change-over switch to "HIGH".

In this mode, automatic idling system is neglected and engine rpm will follow the setting of throttle lever.

(8) Adjust the engine speed. When engine runs at a high speed after warming up, set the speed to the rpm shown in the table.

	Frequency (No load speed)
Operation at 50Hz	52.5Hz (1575rpm)
Operation at 60Hz	62.5Hz (1875rpm)

(9) Adjust the out put voltage to the rating by the voltage regulator.

(10) Turn on the circuit breaker, and electrical power is feed to load.

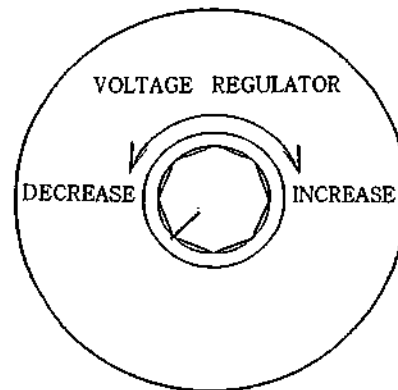
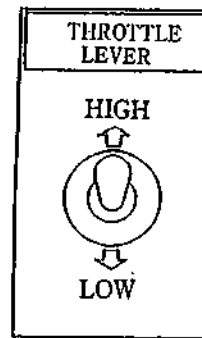
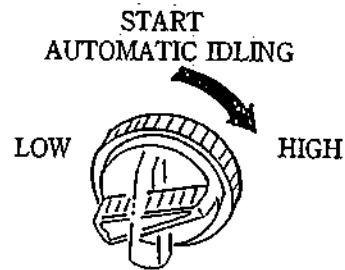
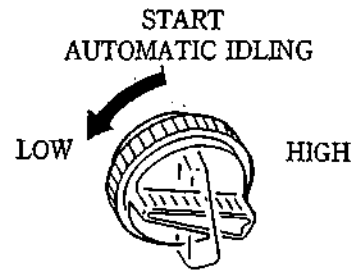

5-3 Starting in the cold weather

This machine is equipped with starting-assist device (APS) for easy starting at cold weather. Please start as following procedure.

- (1) Open the fuel valve for APS (Automatic Priming System). About detail of APS, please read the instruction manual for the engine furnished separately.
Keep it opened throughout the winter while the APS is used.
- (2) Make sure that the circuit breakers of the machine and load are all OFF.
- (3) Set the speed change-over switch in "LOW" position, the frequency change-over switch to the required frequency, the single-parallel change-over switch to desired operation side and the battery switch to ON.
- (4) While depressing the emergency stop button, turn the starter switch to "START" position for approximately 10 seconds, and set the starter switch to "RUN" position.
- (5) Pull the heater switch to ON. Preheat lamp goes on and the preheating starts automatically. After about 80 seconds, the preheat lamp goes out and the preheat has completed.
- (6) After preheat lamp went out, turn the starter switch to "START" position until engine starts. After starting, release the hand from the key, then starter switch is automatically set in the "RUN" position.
- (7) Return the heater switch to OFF as following table.

Temperature	Time from engine starting to heater switch "OFF".	
0°C to 10°C	1 to 2 min.	After starting, turn the heater switch to OFF when the engine rotates smoothly and the color of exhaust gas become normal.
under 0°C	3 to 5 min.	

If you connect the load under the condition heater switch ON, the color of exhaust gas shall be become abnormal and the output shall be lowered. And the life of glowplug shall be shortened. Therefore please turn the heater switch to OFF before connect the load.

[Note]

For the item (5), if you turn the starter switch to "START" when the preheat lamp is lighting, it shall be unable to start the engine because no-spark of glowplug by wet.

When engine shall be unable to start, turn the heater switch to "OFF" and repeat the item (4) to (6) after 2 minutes interval.

In the case of temperature over 13 °C even outer low temperature, the preheat lamp shall be not lighted and the APS shall be not operated.

The engine shall be able to start without APS at the condition over 13 °C temperature.

(8) After warming up operation, turn the speed change-over switch to "START, IDLING" position.

(9) Do the normal operation after the 「 5-2.(7) See p.42 」 .

5-4 Handling during operation

(1) Checking after startup

- ① Make sure that each meter and lamp are normal.

normal : warning lamp is all off

(See p.16)

- ② Make sure that the color of exhaust gases from the engine is normal.

Check for unusual noise and vibration.

Color of exhaust gases

- Colorless or light blue: Normal
- Black: Abnormal, incomplete combustion
- White: Abnormal, combustion of oil due to failure of oil

(2) Adjustment during operation

Set the tachometer and frequency meter to the rated by the throttle lever.

Set the voltmeter to the rated by the voltage regulator.

[Note]

- * Do not turn the speed change-over switch to "LOW" position during load operation, or else, the generator voltage and frequency will go down, resulting in failure in operation of the load device or any other trouble.

Do not turn the battery switch to "OFF" position or do not remove the battery, or else, engine will not stop normally or resulting in trouble of electrical equipment.

5-5 Shut down

- (1) Turn OFF the circuit breaker of the load.
- (2) Turn OFF the circuit breaker of the machine.



- (3) Turn the speed change-over switch to "LOW" position and put the machine in cooling operation for a few minutes.



- (4) Set the starter switch in "Stop" position. The engine will stop immediately.

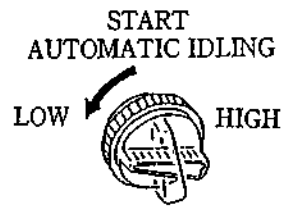

- (5) Turn the battery switch to "OFF".

[Note]

Do not leave the machine keeping the battery switch at "ON", the battery is discharged.

- (6) Remove the key from the starter switch and keep it at hand.
- (7) Check the amount of fuel. Supply fuel if necessary.
- (8) Check for leakage of oil, fuel and water.

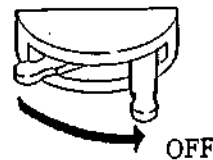
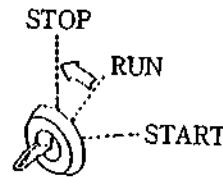

[Note]

For emergency stop, push the emergency stop button until the engine stops.

5-6 Protection device

Protection devices and emergency stop devices are provided for protection of the machine against trouble during operation. When the running caution lamp lights, stop the engine immediately. Check and remove the cause of trouble.

Table of protection device

action warning	turn OFF the circuit breaker	stop the engine	indicate by warning lamp	function
high jacket water temperature (WATER TEMP)	△	○	○	When the cooling water temperature rises abnormally, the device acts. Set point:101°C
oil pressure failure (OIL PRESS)	△	○	○	When the oil pressure falls abnormally, the device acts. Set point:1.0×100kPa
fuel level failure (FUEL LEVEL)	—	—	○	When fuel supply is necessary because of fuel shortage, the device acts.
battery acid level failure (BATT LOW LEVEL)	—	—	○	When the battery acid is failure, the device acts.
oil filter blinding (OIL FILTER)	—	—	○	When replace of oil filter is necessary because of blinding of filter, the device acts.
air filter blinding (AIR FILTER)	—	—	○	When replace or cleaning of air filter is necessary because of blinding of filter, the device acts.
overcurrent	○	—	—	When overcurrent floe, the device acts.

○ : Device acts.

△ : When the single-parallel change-over switch is parallel side, device acts.

6. Parallel operation

[Note]

This section is to explain only the procedures for parallel operation that are different from the general single unit operation. For the same procedures with those for single unit operation, read 「4. Connecting the load See p.26」 and 「5. Operation See p.34」.

In the case where the capacity of the load exceeds that of a generator. The parallel operation is useful by paralleling electrically generators of 2 units or more. However, note that the stable parallel operation requires the equality of output voltages, frequencies, engine governor characteristics, etc. For this reason, it is requested for easy paralleling to select the quite same type of the generating sets for manufacturer, model, etc.

Study this manual carefully before paralleling the units.

6-1 Preparation for parallel operation

- (1) Turn off the main circuit breakers on all the units, and stop the engines.
- (2) Set the voltage change-over board on each unit to the same voltage.
- (3) Connect each unit and load as shown below, referring the terminal symbols. Use a phase tester to check the sequence of the phases.

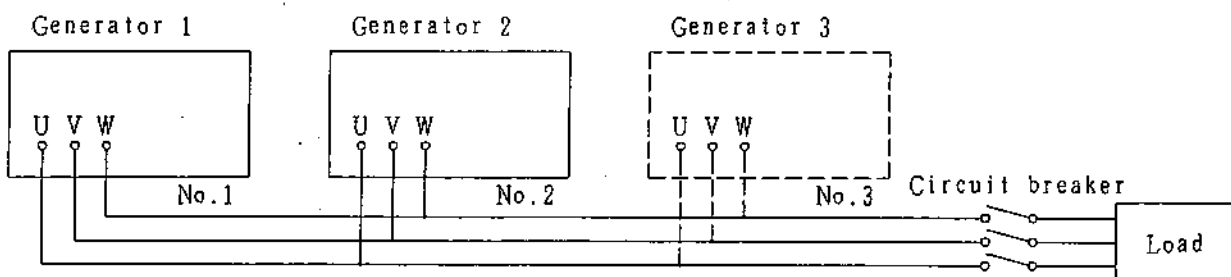

[Note]

Connect the cables in the correct sequence of the 3-phases, seeing the terminal symbols.

- (4) Turn the single-parallel change-over switch on each control panel to "PARALLEL"

6-2 Parallel operation

- (1) Turn off the breakers on the load side.
- (2) Start engine and keep it in warming up.
- (3) Equalize all the voltages and frequencies on the units by adjusting the throttle levers and voltage regulator.

- (4) First turn on the circuit breaker on the No.1 generating set.
- (5) Adjust the throttle lever on the No.2 set so that the two synchronizing lamp on the No.2 set turn on and off synchronizing when the two phase sequences are in the same direction, while the two turn and off alternately when the sequences are in the different direction.
In case the two lamps turn on and off alternately, recheck the cable connections for correct phase sequence.

- (6) At the instance when the synchronizing lamps turn off, turn on the breaker on the No.2 set.

[Note]

The generators can be damaged due to shortcircuit current if the breaker is turned on when the lamps turn on.

- (7) Upon the above procedure, the No.1 and No.2 sets are in parallel operation. The AC ammeters are to indicate zero in this no load condition. If the meters indicate some current, it is an uneffective cross current due to voltage difference. Make it zero by adjusting the voltage regulator.

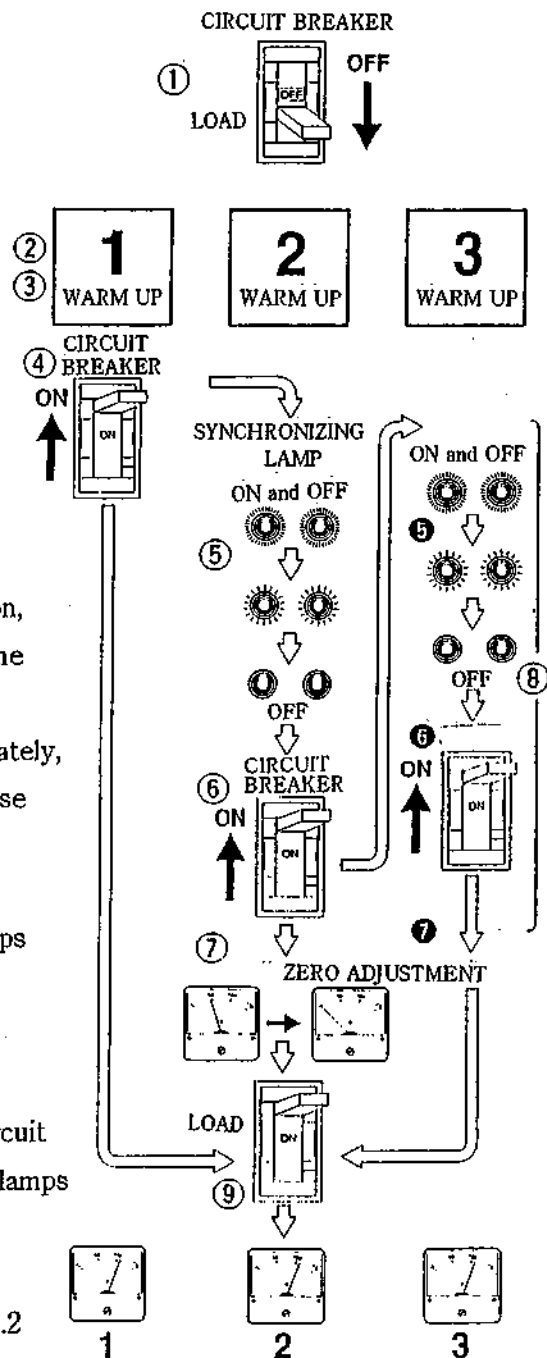

- (8) In the same procedure as the above items (5),(6) and (7), parallel the generating sets of No.3 and so on if any.

- (9) Turn on the breakers on the load side. If each AC ammeters show an imbalance in loading, make it in equal loading by adjusting the throttle lever for engine rpm. The set is to undertake more load sharing when the engine rpm. is adjusted higher, while less sharing when adjusted lower.

[Note] .

AC ammeter indicates the current including a cross current. Watt meter (Option) is required to know the correct load sharing.

6-3 Precautions

- (1) Keep each generating sets in equal load sharing by adjusting the throttle lever for engine rpm. The set is to undertake more load sharing when the engine rpm. is adjusted higher, while less sharing when adjusted lower.
- (2) Keep the single-parallel change-over switch in the position "PARALLEL"

[Note]

If it is turned to "SINGLE", a cross current occurs between the alternators and trips the circuit breakers due to over current.

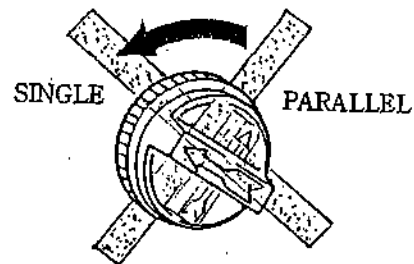

- (3) Watch the fuel level during parallel operation.

[Note]

If fuel runs out during parallel operation, the running set must undertake all loading and may result in an accident in the set or a tripping on the breaker.

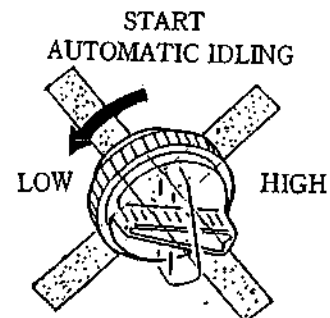

- (4) Never turn the speed change-over switch to the "LOW" side.

[Note]

If it is turned to "LOW" during parallel operation, the running set must undertake all loading and may result in an accident in the set or a tripping on the breaker.

6-4 Shut down

- (1) Turn off the breakers on the load side.
- (2) Turn off the main circuit breaker on each generating set.
- (3) Shut down each engine referring to 「5-5. Shut down See p.46」

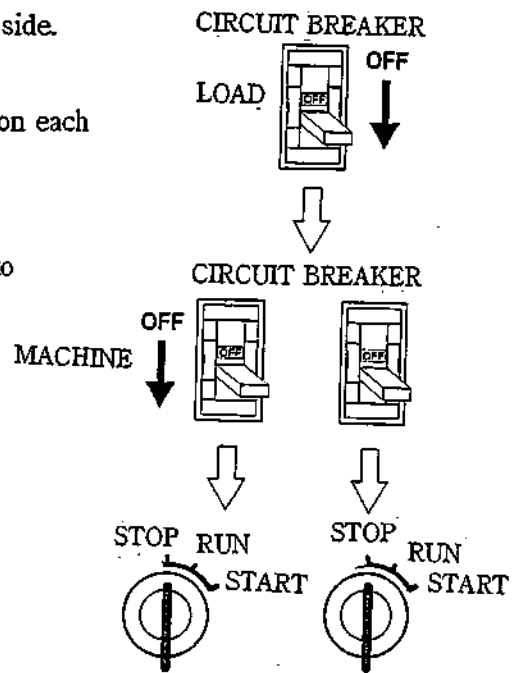

7-2 Cooling water

(1) Cooling water to be used

Soft water likes with less impurities such as tap water can be used as cooling water.

(2) Cooling water used in cold season

When cooling water is likely to be frozen in a cold season, mix it with Long Life Coolant (LLC).

Mixing rate of LLC should be selected within the range of 30–50%. Standard mixing rate of LLC and operating ambient temperature are as shown below.

30%: -10 °C

40%: -20 °C

50%: -30 °C

In general, LLC needs to be replaced after 2 years of use.

(3) Total quantity of cooling water

Total quantity of cooling water : 112 L (include filter capacity : 4.5 L)

7-3 Fuel

(1) Fuel to be used

#2 Diesel Fuel

[Note]

If other kinds of fuel is used or fuel being used contains water or dust, it deteriorates the engine performance or leads to a serious trouble.

7-4 FUEL PIPING SELECTOR

(1) Description of the device

The "Fuel piping selector" selects the supply of fuel to the engine from the machine loaded fuel tank or directly from the outside machine tank through its change-over valve.

(2) Operating procedure

- ① The fuel piping and the change-over valve lever are set as shown in Fig.1 before the machine is shipped. If the fuel is to be supplied from the machine loaded tank, operate the machine with their setting left as such.
- ② If the outside machine tank is to be used for fuel supply, remove the two plugs for connection of the outside machine tank and pipe it as illustrated in Fig.2, then turn the change-over valve in the arrow indicated direction before operating the machine.
- ③ If the outside machine tank is not used with the piping removed from it, be sure to return the change-over valve lever to the position as shown in Fig.1 and screw in the two plugs.

(3) Precaution in piping and operation

- ① For the piping, use an oil resistant pipe with an inside diameter of approximately 8 to 10 mm.
- ② Install the outside machine tank as near to the machine as possible and as the fuel level is within from 0 to +3m for the ground.
- ③ In piping the outside machine tank, leave the position of the change-over valve lever as shown in Fig.1 until the piping is complete before turning it to the position as shown in Fig.2 .
- ④ Set the suction pipe 15 to 20mm above the tank bottom to prevent it from drawing in water and/or foreign matter present in the tank. (See Section A in Fig.2 .)
- ⑤ Take good care to avoid entry of water and or foreign matter into outside machine tank.
- ⑥ Improper handling of changing over the lever, it may cause to overflow the fuel from the fuel tank loaded on the machine or connection of outside fuel tank to the outside of the machine, operate the lever in accordance with the figure.

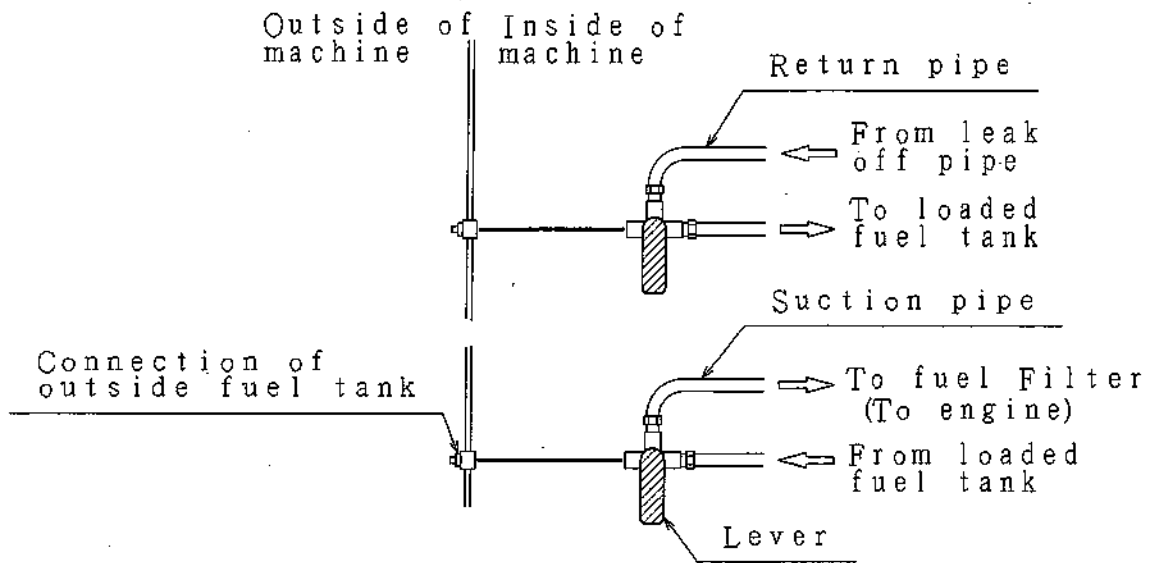

Fig.1 Use of loaded fuel tank

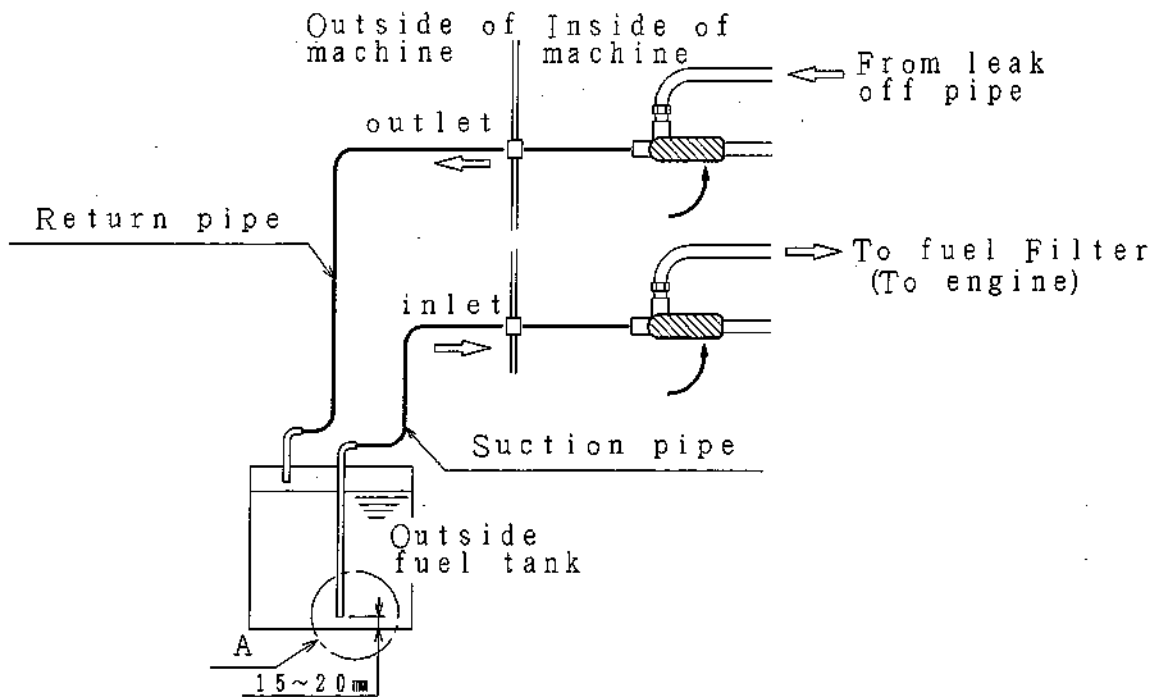

Fig.2 Use of outside fuel tank

8. Handling of battery

⚠ CAUTION

BATTERY

- Battery generates flammable gases.

Improper handling may lead to explosion or serious injury.

- * Battery should be charged in a well ventilated location. Otherwise, flammable gases are accumulated which may be ignited and exploded.
- * When connecting a booster cable, do not jumper the terminals (+ and -). Otherwise, the flammable gases generated from the battery may be ignited and exploded by sparks.
- * For maintenance of the machine, disconnect the cable on the ground side.

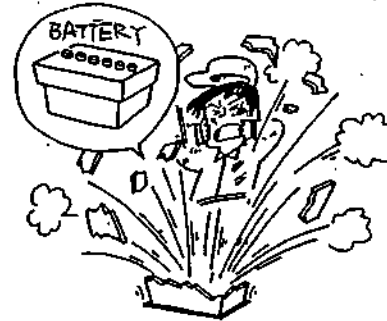
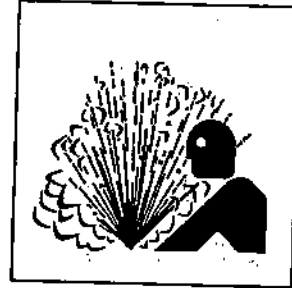

- The battery acid is dilute sulfuric acid. Improper handling will cause unexpected burns.

* When the battery acid gets on your clothes or skin, wash it out with a large volume of water immediately. If it gets in your eyes, wash with a large volume of water immediately and consult your doctor.

– In the worst case, it will put out your eyes.

- For checking or handling of the battery, be sure to stop the engine and turn OFF the battery switch in advance.

8-1 Caution on battery charge

Charging of loaded battery

- * Disconnect the wiring cable from the battery terminals before charging. (Otherwise, the alternator may be damaged due to unusual voltage applied to the alternator)
- * When disconnecting the wiring cables from the battery terminals, remove the ground cable first. (If a tool touches the space between the "+" terminal and the machine, electric spark will occur which is very dangerous)
When connecting the wiring cables to the battery terminals, connect the ground cable last.
- * While the battery is being charged, open all the liquid plugs to discharge the gas.
Keep the battery away from fire to prevent unexpected explosion.
Handle the battery carefully to prevent electric sparks.
- * If the battery is overheated (liquid temperature above 45 °C), stop charging for a while.
- * At the completion of charging, stop charging immediately.
(The relation between battery charge condition and specific gravity See p.68)

If the battery is still charged, the following trouble will occur.

- 1) Battery overheat
 - 2) Decrease in battery acid
 - 3) Deterioration of battery performance
- * Do not connect the battery polarity in reverse (connection of "+" and "-" or "-" and "+") to prevent damage to the alternator or the like.

8-2 Connection of booster cable, and installation

When the engine is started using booster cables, connect the cables as follows.

(1) Connection of booster cable

- ① Connect the clip of the booster cable "A" to the terminal "+" of the machine in trouble.
- ② Connect the other clip of the booster cable "A" to the terminal "+" of normal machine.
- ③ Connect the clip of the booster cable "B" to the terminal "-" of normal machine.
- ④ Connect the other clip of the booster cable "B" to the engine block of the machine in trouble.

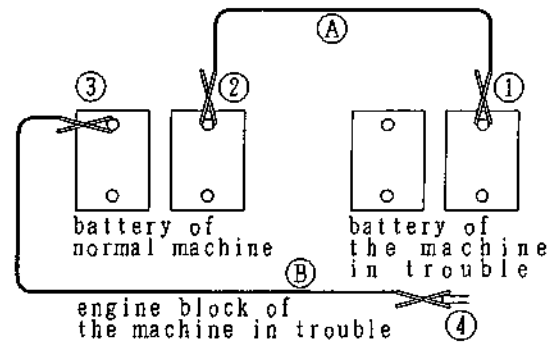

(2) Removal of booster cable

- ① Remove the clip of the booster cable "B" connected to the engine block of the machine in trouble.
- ② Remove the clip of the booster cable "B" connected to the terminal "-" of normal machine.
- ③ Remove the clip of the booster cable "A" connected to the terminal "+" of normal machine.
- ④ Remove the clip of the booster cable "A" connected to the terminal "+" of the machine in trouble.

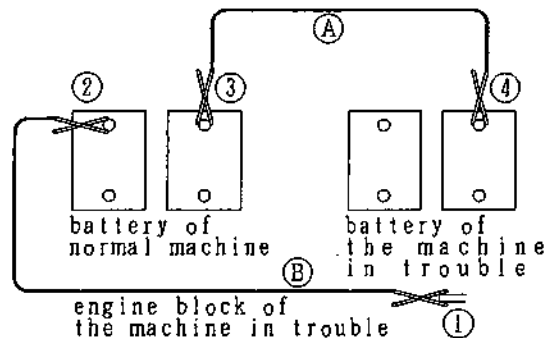

(3) Caution on handling of booster cable

- ① Use booster cables and clips of the size that matches the size of battery.
- ② The battery used for normal machine should be the same in capacity as the battery of the machine in trouble.
- ③ After connection, check that clips are firmly connected.
- ④ When connecting booster cables, make sure that the terminal "+" does not touch the terminal "-".
- ⑤ The engine block should be connected at a place more than 30cm away from the battery.

9. Periodical checking and maintenance

(Read the instruction manual for the engine furnished separately)

⚠ WARNING MOVING PARTS can cause severe injury.

- Rotary unit which moving parts at a high speed is located in the machine.

Care should be taken during operation.

- * When the machine needs checking or maintenance, be sure to stop it in advance.

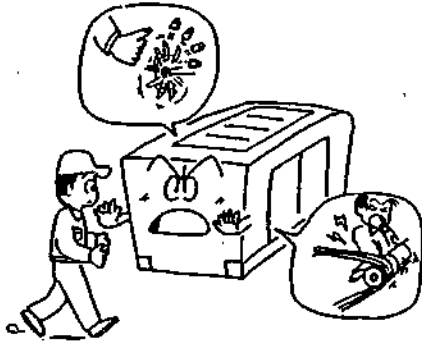
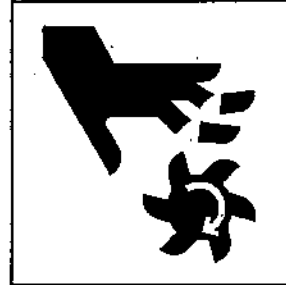

⚠ WARNING ELECTRIC SHOCK can kill.

- High voltage units are located in the machine.

Care should be taken during operation.

- * When the machine needs checking or maintenance, be sure to stop it in advance.

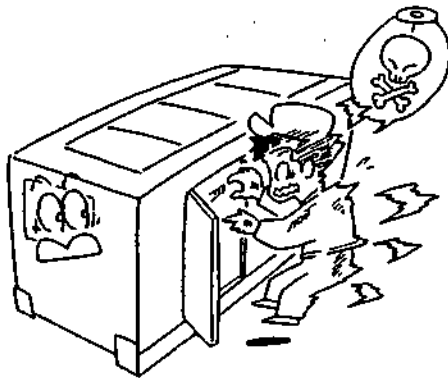

⚠ CAUTION HOT PARTS can burn skin.

■ High temperature parts are located in the machine.

Care should be taken during operation.

* When the machine needs inspection or maintenance, be sure to stop it in advance.

* Even after the machine stops, the inside of the bonnet is still hot.

Wait until the engine is cooled sufficiently.

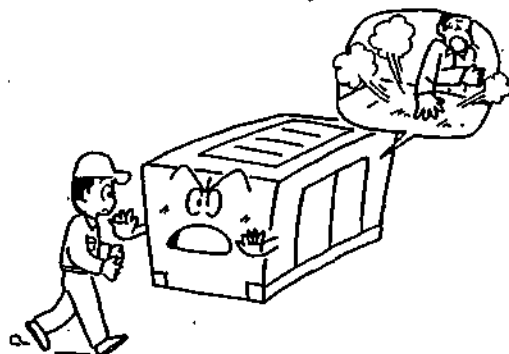
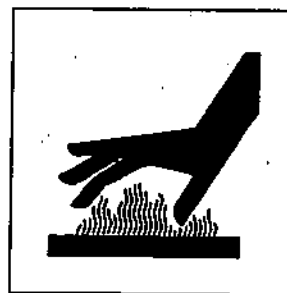

⚠ CAUTION BATTERY

■ Battery generates flammable gases.

Improper handling may lead to explosion or serious injury.

* For maintenance of the machine, disconnect the cable on the ground side.

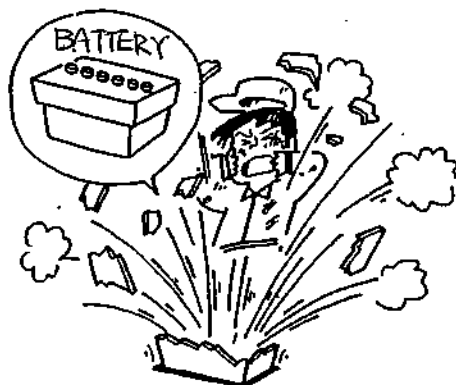
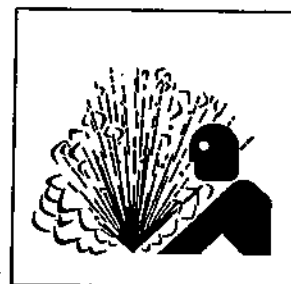

⚠ CAUTION Sign for maintenance

- * During checking or maintenance, be sure to put up a sign "Under maintenance" at a conspicuous place such as the starter switch to prevent the machine from being operated by other persons.

⚠ CAUTION Safety clothes

- * During checking or maintenance, be sure to put on suitable clothes and protectors.
- * Do not put on baggy clothes, necklace, etc., because they are easily caught by projections which may cause injuries.

⚠ CAUTION Handling of waste liquid

- * Waste liquid from the machine should be received in a vessel.
- * Do not dispose of waste liquid recklessly, as it causes environment pollution.
Do not throw it on the ground or in rivers, lakes, sea, etc.
- * Lubrication, fuel, cooling water (coolant) and other harmful objects such as filter, battery, etc., should be disposed of according to the related regulations.

9-1 Maintenance schedule

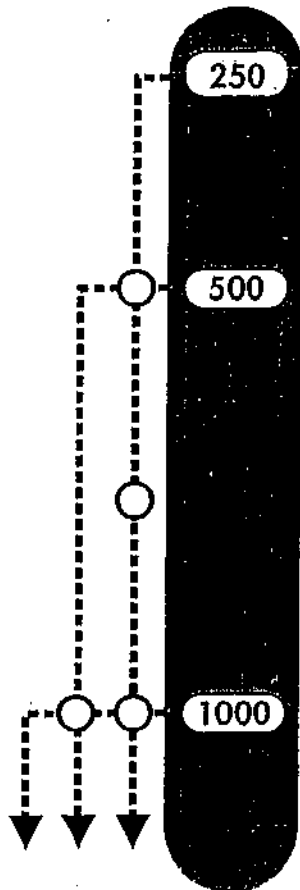

250 hours: Checking/every 250 hours

- * Replacement of engine oil
- * Replacement of engine oil filter element
- * Cleaning of air cleaner element
- * Measurement of generator insulation resistance (once a month)
- * Checking on battery specific gravity
- * Replacement of fuel filter cartridge (only first 250 hours)

500 hours: Checking/every 500 hours

- * Replacement of fuel filter cartridge
- * Cleaning of radiator
- * Checking for terminal and connection of the circuit
- * Checking on generator bearing
- * Checking/every 250 hours is also required.

1000 hours: Checking/every 1000 hours

- * Cleaning inside fuel tank
- * Replacement of air cleaner element
- * Replacement of corrosion resistor cartridge
- * Checking on rubber suspension
- * Checking on nylon and rubber hose
- * Checking on lining
- * Checking/every 250 and 500 hours are also required.

On the engine system, main checking items only are shown in this manual.

For details, refer to the instruction manual for the engine furnished separately.

9-2 Checking/every 250 hours

(1) Replacement of engine oil

This machine is equipped with special pump for oil replacement. Replace engine oil in the following procedure;

- ① Remove the drain plug at the bottom of the oil pump.
- ② Connect a hose of the 19 mm inside diameter to the oil exit port of the pump, and arrange an oil receiver.
- ③ Remove the plug on the pump, and prime engine oil. Without this procedure, the pump can not suction oil and may result in a trouble. After completing the oil priming, fit and tighten the plug.
- ④ Turn on the battery switch.
- ⑤ Turn on the switch on the oil pump to suction the oil from the pump.
- ⑥ After seeing no more oil comes out, turn off the switch on the pump.

[Note]

Do not allow a no load operation of the pump. Do not run the pump continuously for more than 25 minutes since it is the rating.

- ⑦ Turn off the battery switch.
- ⑧ Fit and tighten the drain plug at the pump.
- ⑨ Fill new engine oil into the oil filler port up to the H level of the dipstick. For volume of the oil, refer to 「 7-1 Engine oil See p.53 」
- ⑩ After filling engine oil, run the engine for a few minutes and stop it. Then check that oil level again to be between the L and H levels. 「 5-1.(1) Checking on engine oil See p.35 」

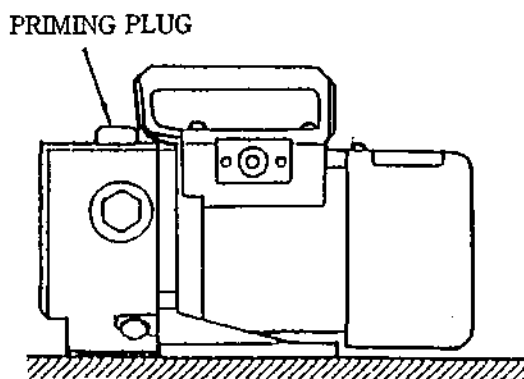

(2) Replacement of engine oil filter element

① Remove the cartridge type element (cartridge) using filter wrench.

② Clean the filter base. Coat the packing of new cartridge with engine oil thin. Then, mount the cartridge.

- When mounting, tighten the cartridge from 3/4 to 1 turn by using filter wrench after the packing is fitted to the seal of the filter base.

③ After the element is replaced, run the engine for a while. Then, check to see that oil is supplied to the level between H and L .

「 5-1.(1) Checking on engine oil See p.35」

Parts number of oil filter cartridge :

KOMATSU 600-211-1231 (Two elements are used.)

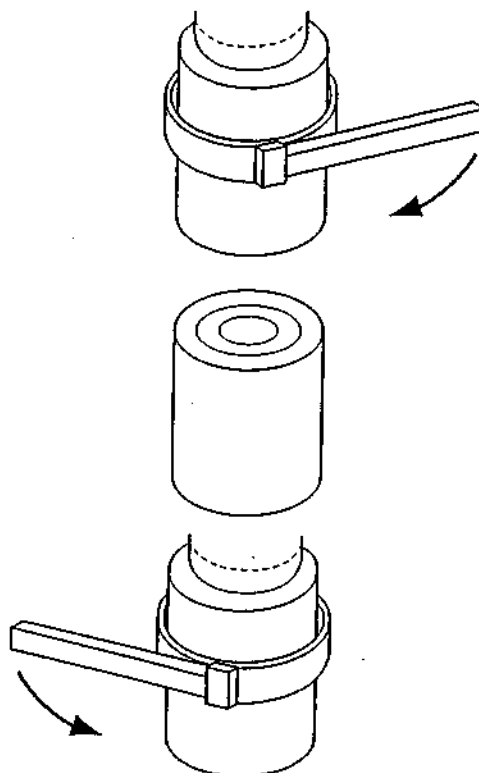

(3) Cleaning of air cleaner element

This element should be cleaned, regardless of operating time, when the warning lamp of "Air filter blinding" goes on.

– Dry dust clings on element –

Remove the air cleaner element and clean the element with dry and clean compressed air.

- * While it is being cleaned, check the element for any damage. Replace if necessary.
- * Before installing the air cleaner, wipe off dirt on the element cover.
- * When insert the element, insert the element completely pressing equal edge of element.
- * If the warning lamp of "Air filter blinding" goes on immediately after cleaning of element, replace it.

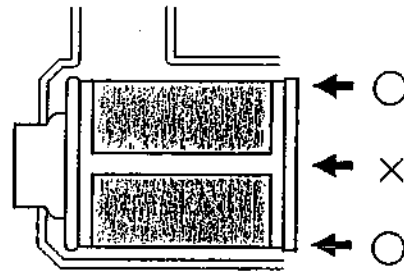
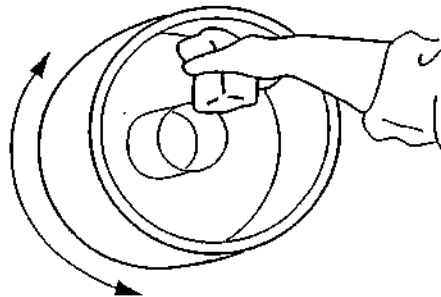
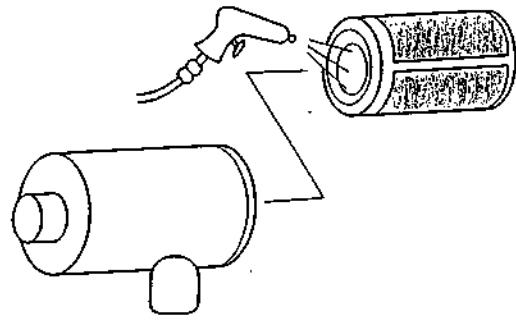

(4) Measurement of insulation resistance.

⚠ WARNING ELECTRIC SHOCK can kill.

* Measurement should be made after the machine stops.

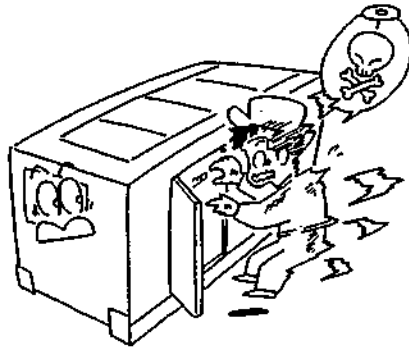

- Using a 500V megger, make a check once a month to ensure that the insulation resistance is more than $1M \Omega$.

Measurement:

Disconnect the load side cable from the output terminal as shown at below. Turn ON the circuit breaker and measure the insulation resistance between the output terminal bolt and the bonnet.

- If the measured resistance is less than $1M \Omega$, it may cause electric leakage or fire accident. Wipe off dirt and oil on the output terminals, circuit breakers and generator leads (cables) and dry them thoroughly.

If the insulation resistance is not recovered after cleaning, contact distributor or our office.

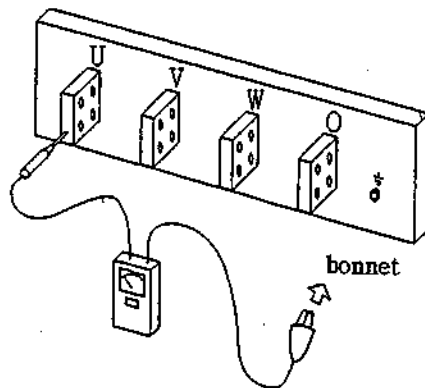

(5) Check on battery specific gravity.

If battery is likely to be discharged due to failure in startup of the engine, measure the specific gravity of battery acid.

The relation between battery charge condition (charging rate) and specific gravity is as shown below.

Charging rate (%) \ Liquid temp. °C	20	0	-10
100	1.28	1.29	1.30
90	1.26	1.27	1.28
80	1.24	1.25	1.26
75	1.23	1.24	1.25

Each value has a deviation of ± 0.01 .

When the charging rate is below 75%, the battery needs to be recharged.

「 8-1. Caution on battery charge See p.58 」

(6) Replacement of fuel filter cartridge

Replace the fuel filter cartridge at only first 250hours.

「 9-3.(1) Replacement of fuel filter cartridge See p.69 」

9-3 Checking/every 500 hours

Checking/every 250 hours is also required.

(1) Replacement of fuel filter cartridge.

- ① Remove the cartridge type element (cartridge) using filter wrench.
- ② Clean the filter base. Coat the packing of new cartridge with engine oil thin. Then, mount the cartridge.
 - When mounting, tighten the cartridge about from 1/2 to 3/4 turn by hand after the packing is fitted to the seal of the filter base.
- ③ After the cartridge is replaced, discharge air in the fuel piping.
 - For details, refer to the instruction manual for the engine. A nameplate showing the method of discharging air is also attached to the machine.

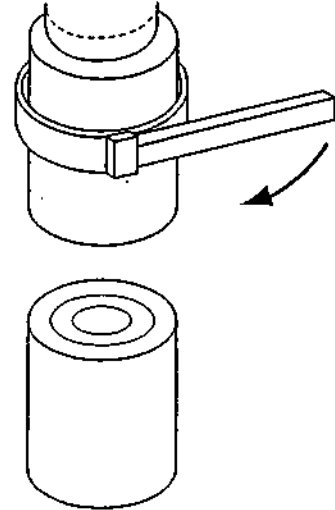

Parts-number of fuel filter cartridge :

KOMATSU 600-311-7111 (Two elements are used.)

(2) Cleaning of radiator

When the fin or tube is blinded, it should be cleaned with steam or high pressure water.

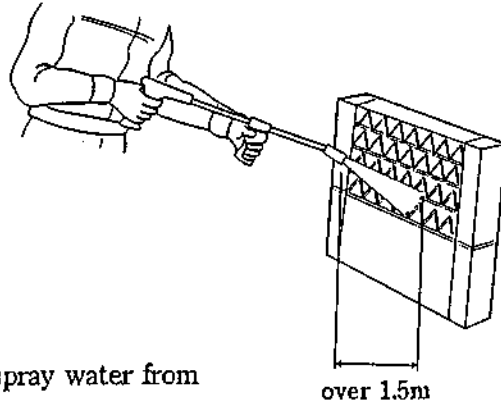

[Note]

When a high pressure washer is used, spray water from a place about 1.5m away to prevent damage to the fin or tube.

(3) Checking for terminal and connection of the circuit.

Check for main and sub circuit, whether there are no abnormality such as loosening, corrosion and burning, etc.

(4) Checking on generator bearing

Check and supply the grease of bearing. About 1/3 of bearing chamber volume is proper for grease quantity.

If thermo label changes color to black showing high temperature, replace the bearing.

9-4 Checking/every 1000 hours

Checking/every 250 and 500 hours is also required.

(1) Cleaning inside fuel tank

Drain the fuel in the fuel tank completely, and wash out deposits and water collected inside the tank.

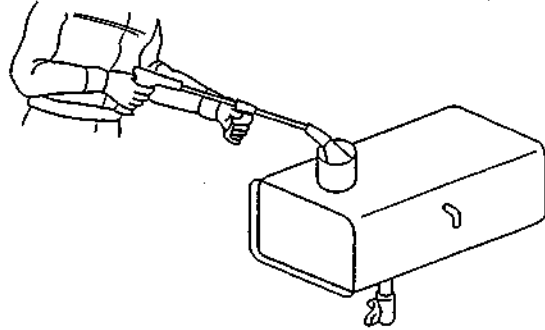

(2) Replacement of air cleaner element

The element should be replaced referring to 「9-2.(3) Cleaning of air cleaner element See p.66」.

Parts number of oil filter cartridge :

KOMATSU 600-181-4300 (Two elements are used.)

(3) Replacement of corrosion resistor cartridge

- ① Close the valve on the corrosion resistor cartridge.
- ② Remove the cartridge type element(cartridge) using filter wrench.
- ③ Clean the filter base. Coat the packing of new cartridge with engine oil thin. Then, mount the cartridge.

- When mounting, tighten the cartridge about from 2/3 turn by hand after the packing is fitted to the seal of the filter base.

- ④ After the cartridge is replaced, open the valve on the corrosion resistor cartridge.

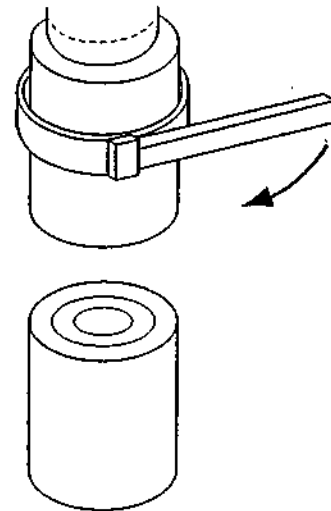

Parts number of oil filter cartridge :

KOMATSU 600-411-1161 (One element is used.)

(4) Checking on rubber suspension

Check on the rubber suspension, whether it is damaged or deformed by the oil. Contact distributor or our office to replace the rubber suspension, if necessary.

(5) Checking on nylon and rubber hose

Check on the nylon and rubber hose, whether they are hardened or deteriorate. Contact distributor or our office to replace the nylon hose and rubber hose, if necessary.

(6) Checking on lining

Check on the lining, whether it deteriorates greatly, or it is stained by clinging of oil or the like, or it is removed. Contact distributor or our office to replace the lining, if necessary.

9-5 Table of periodical maintenance and checking

Please read "Engine Instruction Manual" furnished separately.

◇ :Check or Clean ○ :Replacement ☆ :Only first time

	List of maintenance and inspection	daily	every 250h	every 500h	every 1000h
Engine	Checking on oil level and stain of oil	◇			
	Checking on cooling water	◇			
	Checking on fan belt	◇			
	Checking on fuel and drain	◇			
	Checking on battery acid level	◇			
	Checking on for water and oil leakage	◇			
	Checking on bolts and nuts for looseness	◇			
	Checking on exhaust color, sound and vibration	◇			
	Checking on meters and warning lamps	◇			
	Replacement of engine oil		○		
	Replacement of engine oil filter cartridge		○		
	Clean air cleaner element		◇		
	Checking on specific gravity of battery		◇		
	Cleaning radiator			◇	
	Replacement of fuel filter		☆ ○	○	
	Cleaning fuel tank				◇
	Replacement of air cleaner element				○
	Replacement of corrosion resistor cartridge				○
	Checking on rubber suspension				◇
Checking on nylon and rubber hose				◇	
Checking on lining				◇	
Generator	Checking on generator case grounding	◇			
	Checking on insulation resistance		◇		
	Checking on terminal and connected section			◇	
	Checking on generator bearing			◇	

※ Contact distributor or our office.

☆ This symbol represent first time of inspection, next time is ordinary schedule.

10. Troubleshooting

Please read "Engine Instruction Manual" furnished separately.

⚠ WARNING MOVING PARTS can cause severe injury.

- Rotary unit which moving parts at a high speed is located in the machine.

Care should be taken during operation.

- * When the machine needs checking or maintenance, be sure to stop it in advance.

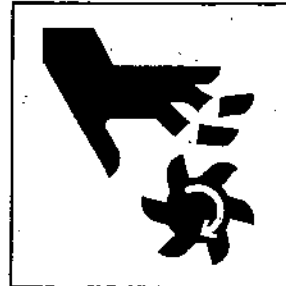
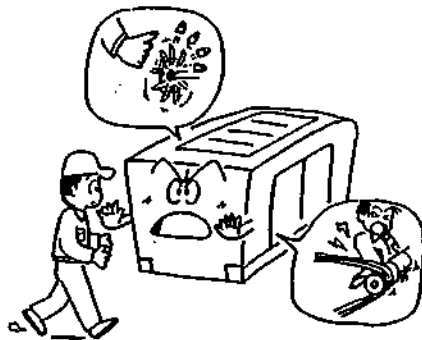

⚠ WARNING ELECTRIC SHOCK can kill.

- High voltage units are located in the machine.

Care should be taken during operation.

- * When the machine needs checking or maintenance, be sure to stop it in advance.

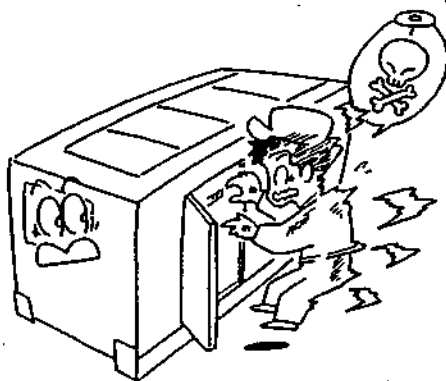

⚠ CAUTION HOT PARTS can burn skin.

- High temperature parts are located in the machine.

Care should be taken during operation.

- * When the machine needs inspection or maintenance, be sure to stop it in advance.
- * Even after the machine stops, the inside of the bonnet is still hot.

Wait until the engine is cooled sufficiently.

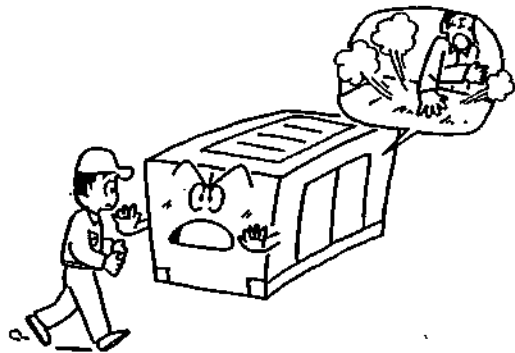
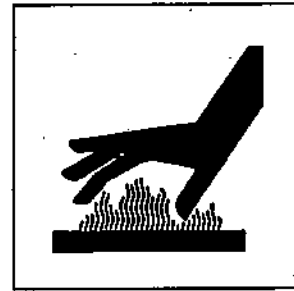

⚠ CAUTION BATTERY

- Battery generates flammable gases.

Improper handling may lead to explosion or serious injury.

- * For maintenance of the machine, disconnect the cable on the ground side.



Phenomenon		Assumed cause	Action
Engine will not start up	Cell motor will not run or revolution speed is low	Discharged battery	Charge or replace
		Detached or loosened or corroded battery terminal	Repair
		Battery switch set at OFF position	Turn ON
		Improper starter switch	Replace
		Improper starter	Replace
		Broken lead wire	Repair
	Cell motor runs	Fuel shortage	Supply
		Blinded fuel filter	Replace element
		Air in fuel system	Remove
Speed will not rise	Air in fuel system	Remove	
	Blinded fuel filter	Replace element	
	Compression failure	Repair engine	
	Blinded air cleaner	Replace element	
Engine stop by oil failure	Oil shortage	Supply	
	Oil pressure switch failure	Replace	
	Blinded oil filter	Replace element	
High jacket water temperature	Cooling water shortage	Supply	
	Fan belt looseness	Adjust	
	Blinded core of radiator	Clean	
	Engine thermostat failure	Repair	
Voltmeter will not operate	Voltmeter failure	Replace	
	AVR failure	Contact distributor or our office	
	Burned ZNR		
	Quenched residual magnetism (Except 25SP)		
	Burned rotary rectifier		
	Disconnected rotor wiring		
	Burned generator wiring		
Rated voltage will not be reached	Voltmeter failure	Replace	
	AVR failure	Contact distributor or our office	
	VR failure		
	Burned rotary rectifier		
	Burned ZNR		
	Burned generator wiring		
	Low speed	Increase	

Phenomenon	Assumed cause	Action
Voltage goes too high	Voltmeter failure	Replace
	AVR failure	Contact distributor or our office
	VR failure	
Applied load causes load voltage drop	Burned rotary rectifier	Contact distributor or our office
	AVR failure	
	Burned main field, exciter field wiring	
	Unbalanced load	Balance

11. Long-term storage

When the machine is to be stored for a long period of time, choose a cool place free from moisture and dust, and observe the following points.

- (1) Remove dirt clinged the machine and clean it thoroughly.
If painting is peeled off, it should be repaired.
- (2) Remove the battery from the machine. The battery should be charged completely before it is stored.
 - Battery is discharged of itself. Recharge it once a month.
- (3) If any defects are found, check and repair the machine so that it can be used for future operation.
- (4) For details of handling the engine, refer to "Engine Instruction Manual" furnished separately.

CAUTION

Stacking

- Improper stacking of machines may cause falling or dropping accidents.

When stacking other machines on this machine, be sure to observe the following points.

- * Check that the bonnet of the machine is free from damage and that the fixing bolts are not loosened and missing.
- * Put the machine horizontally on a solid foundation which withstands the weight of stacked machines.
- * Machines can be stacked up to 2 stages. The weight and size of stacked machines should be less than those of this machine.
- * Using square timbers as shown right, put each machine making sure that the weight is even.

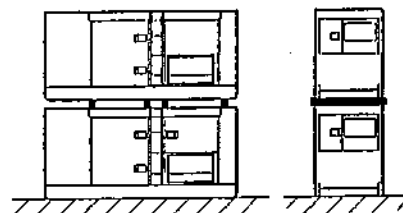

- Do not operate the machines in the state of stacking to prevent falling or dropping accidents.

12. Service data

12-1 Specifications

	MODEL	DCA-600SPK
A C	MODEL	DF-6600
	FREQUENCY	50/60 Hz
G E	RATED OUTPUT	550/600 kVA 440/480 kW
	RATED VOLTAGE	200/220 V or 400/440 V
N E	RATED CURRENT	1588/1575 A or 794/787 A
	POWER FACTOR	0.8 (lagging)
R A	NO.OF PHASES	Three-phase(four wire)
	EXCITATION	Brushless type (with automatic voltage regulator)
T O	NO.OF POLES	4
	SPEED	1500 / 1800 min ⁻¹ {rpm}
R	INSULATION	class F
	MANUFACTURE	KOMATSU
E N G I N E	MODEL	SACD170-A
	TYPE	4cycle, water cooled diesel engine, direct injection, turbocharger with aftercooler
I N E	NO.OF CYLINDERS	6-
	BORE×STROKE (mm)	170×170
E	TOTAL DISPLACEMENT	23.15 L
	RATED OUTPUT (1500/1800min ⁻¹)	470/513 kW 639/698 PS
S E T	BATTERY (DOMESTIC STANDARD)	190H52×2
	FUEL	DIESEL FUEL ASTM No.2 or equivalent
E N G I N E	FUEL TANK CAP.	490 L
	ENGINE OIL	OVERALL 119 L
I N E	QUANTITY*1	FILTER 6.1 L
	COOLANT	OVERALL 112 L
S E T	QUANTITY*2	RESERVE TANK 4.5 L
	LENGTH OVERALL*3	5580 mm
I N E	WIDTH OVERALL	1650 mm
	HEIGHT	2400 mm
S E T	DRY WEIGHT	8860 kg
	TOTAL WEIGHT	9780 kg

The above specifications and set dimensions are subject to change.

*1 Overall of engine oil contains filter.

*2 Overall of coolant quantity contains reserve tank.

*3 Overall of length contains length of roof, about detail, refer to 「12-2. Outline drawing See p.80」.

Dry wight : This weight does not contain the cooling water, engine oil and fuel.

Total weight : This weight contains the cooling water, engine oil and fuel.

• AC generator specifications (for custom voltage)

Rated output	kVA kW	50Hz			60Hz		
		550	550	550	600	600	600
		440	440	440	480	480	480
Rated voltage (V)		190/380	415	220/440	190/380	200/400	240/480
Rated current (A)		1671/836	765	1443/722	1823/912	1732/866	1443/722

12-2 Outline drawing

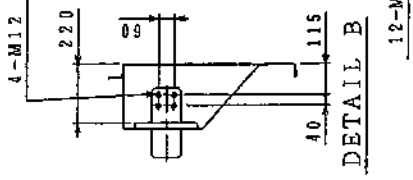
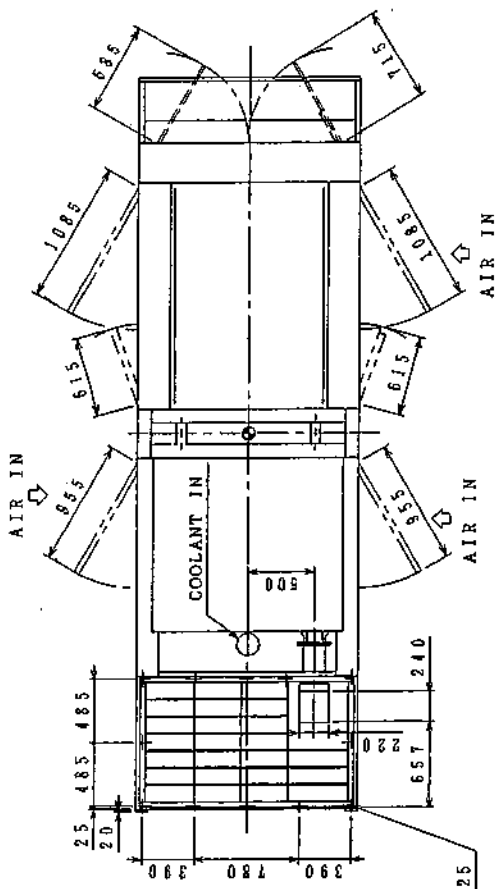
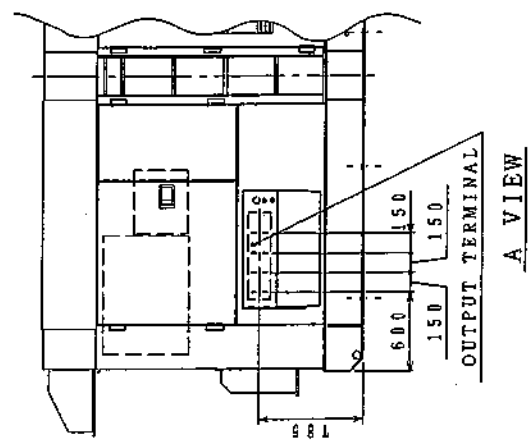

HEATED AIR AND EXHAUST GAS OUT

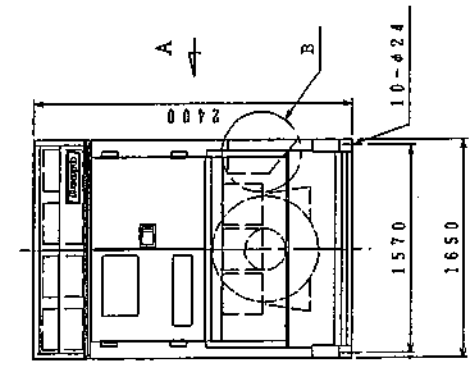
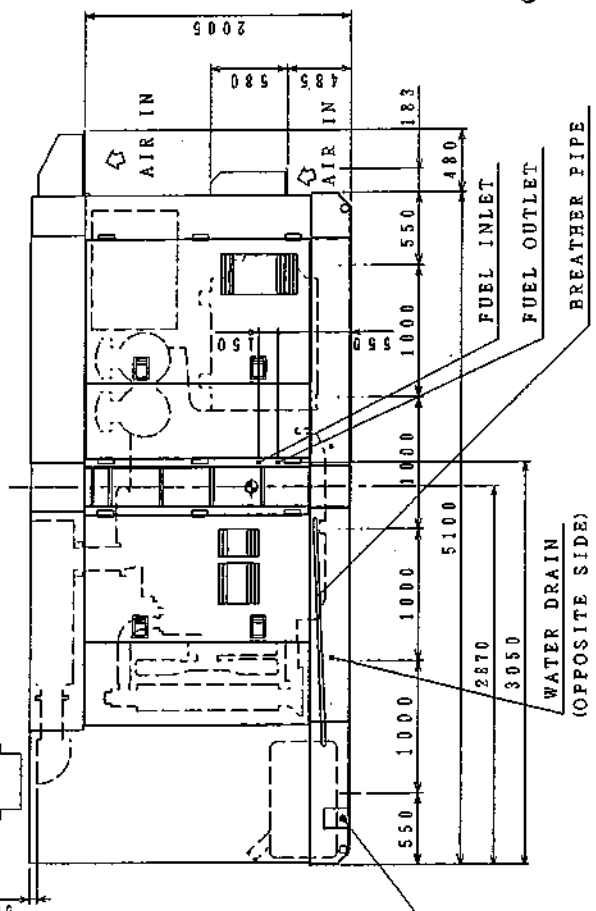

⊙ : CENTER OF GRAVITY

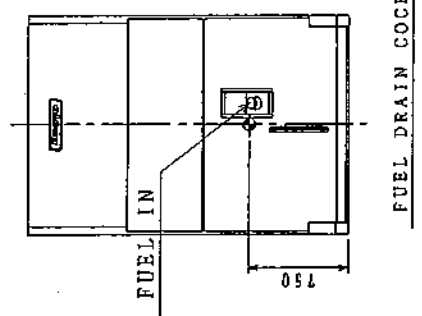

12-4 Engine wiring diagram

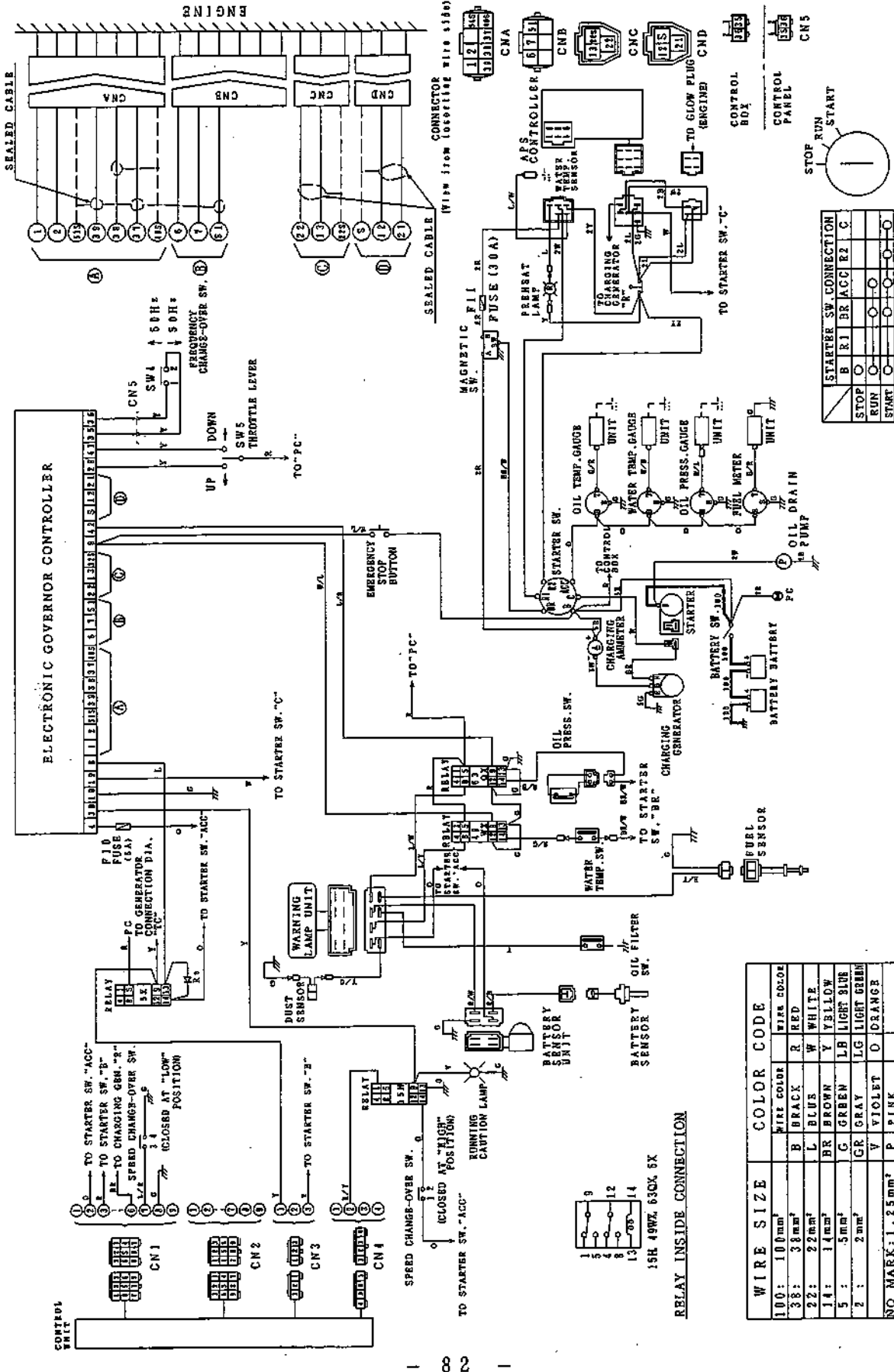

RELAY INSIDE CONNECTION

1	2	3	4	5	6	7	8	9	10	11	12	13	14
TO STARTER SW "ACC"	TO STARTER SW "R"	TO STARTER SW "L"	TO STARTER SW "G"	TO STARTER SW "B"	TO STARTER SW "Y"	TO STARTER SW "BR"	TO STARTER SW "GR"	TO STARTER SW "V"	TO STARTER SW "P"	TO STARTER SW "O"	TO STARTER SW "C"	TO STARTER SW "R1"	TO STARTER SW "R2"

WIRE SIZE	COLOR CODE
100: 100mm²	WIRE COLOR
38: 38mm²	R RED
22: 22mm²	B BRACK
14: 14mm²	L BLUS
5: 5mm²	BR BROWN
2: 2mm²	G GREEN
	LB LIGHT BLUE
	LG LIGHT GREEN
	GR GRAY
	V VIOLET
	O ORANGE
	P PINK

NO MARK: 1.25mm²

STARTER SW CONNECTION

STOP	R	R1	BE	ACC	R2	C
RUN	○	○	○	○	○	○
START	○	○	○	○	○	○

13. Options instruction manual

If equipment the option device to the machine after the purchase is required, contact distributor or our office.

If the machine is modified on your own, the warranty of manufacturer will become invalid.

13-1 AUTOMATIC OILER

(1) Description of the device

This device is designed to maintain the engine oil consumed during operation at a proper level.

(2) System of the device

- ① This device uses an oil level regulator. This regulator is normally installed on the side of the oil pan. The oil level is controlled by the solenoid valve (valve) and float on the communicating tube.
- ② If oil is consumed and oil level is low, valve opens and supply the oil from oil tank.
- ③ When the machine stops, the oil is not supplied by the valve on the communicating tube. When the machine is running, the valve opens and lubrication is possible.
- ④ The oil level regulator is provided with the oil level, to check the change of oil level in the oil pan.

(Connection of the oiler)

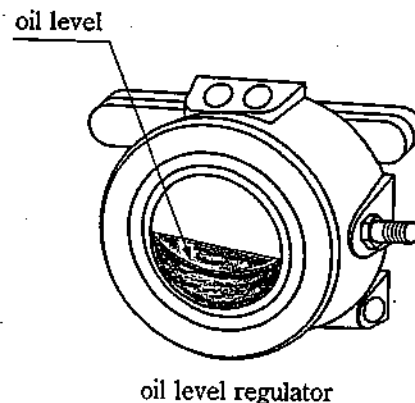
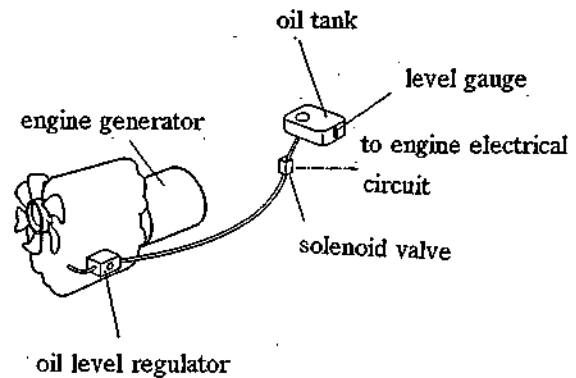

(3) Handling of the device

- ① Supply oil to the oil tank. (Oil tank capacity is about 45 L.)
- ② Check the oil level by the oil level gauge of the oil tank as daily checking and supply oil before oil tank is empty. When oil in the oil tank is running low, warning lamp of the oil tank level on the operating panel goes on, and it should be supplied at the tank.
- ③ Check the oil level in the oil pan by the dipstick once a week, although this device is equipped. 「 5-1 (1) Checking on engine oil See p.35 」
- ④ Replacement time and replacement procedure of oil is same as the machine does not equip this device. 「 9-2 (1) Replacement of engine oil See p.64 」

(5) Precaution in the handling of the device

- ① Oil uses same as in the oil pan.
- ② Install the machine, its inclination is held within 3 degrees.
- ③ Do not change the location of the oil level regulator. Because the oil level in the oil pan is set by the location of the oil level regulator.
- ④ If the piping system is clogged with dust, clean the oil tank drain and piping.

13-2 EARTH LEAKAGE RELAY

⚠ WARNING

ELECTRIC SHOCK by leak can kill.

- Improper grounding may lead to death due to electric shock. Because the device for leakage protection does not operate effectively.

* Grounding terminal for the earth leakage relay, case grounding terminal and case of the load must be grounded individually.



(1) Description of the device

The machine is provided with an earth leakage relay to detect any leakage produced due to such trouble as insulation failure of the load during operation and to cut off the circuit for protection against any accident such as electrocution resulting from the trouble.

This relay detects any leakage and it immediately trips the circuit breaker when that leakage occurs.

The set current values and the tripping times are changeable as shown at the table 1 and 2.

Improper handling of the relay may lead to unsafe condition in comparison with that does not use the relay. Please read this manual carefully to avoid an improper handling.

To ensure further safety, install an earth leakage breaker for each load at the position near the load.

Pilot lamp (green) Earth leakage lamp (red)

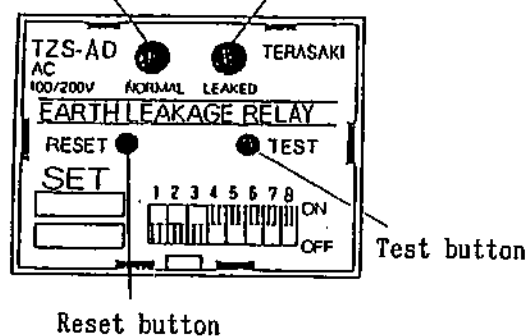

[Note]

The set current value can be made as per your request. However, please consult with us because the necessary grounding resistance value may differ if the set value is changed.

Also, if set current value exceeds 30mA (100, 300, 500, 1000mA), it becomes insufficient for an electrical shock prevention. In that case, provide an earth leakage breaker of the set value 30mA or less to each load.

(2) Rated set current value and the change over of the tripping time

The earth leakage relay has setting selection in range of tables 1 and 2 by changing over the slide switch mode of the rated set current value and the tripping time.

Table 1. setting of the rated current

set current	slide switch mode				
	switch	1	2	3	4
30 mA 0.04 sec. or less	ON OFF		*1		
100 mA	ON OFF				
300 mA	ON OFF				
500 mA	ON OFF				
1000 mA	ON OFF				

Table 2. setting of the tripping time

set time	slide switch mode				
	switch	1	2	3	4
0.04 sec. or less	ON OFF				
0.3 sec. (0.2 to 0.36)	ON OFF				
0.5 sec. (0.4 to 0.6)	ON OFF				
1 sec (0.8 to 1.2)	ON OFF				
2 sec (1.3 to 2)	ON OFF				

[Note]

*1 This mode (switch 1 at ON) is given precedence to other switches 2 to 8.

(3) How to change over

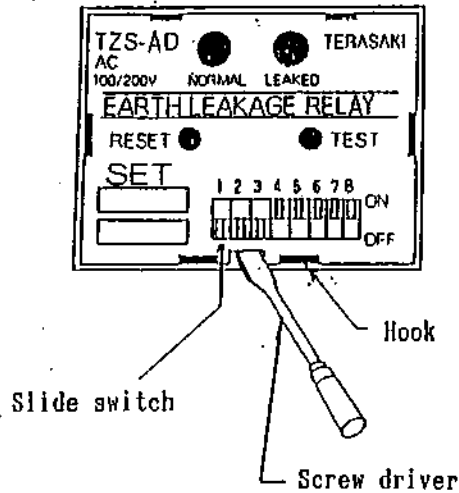

- ① Remove the transparent cover. As shown left, push up the pit softly by a screw driver to take the hook off.
- ② Make sure the slide switch mode of the requested set current value and the tripping time mentioned on the table 1 and 2, or on the name plate.
- ③ Change over the slide switch knob to the confirmed mode. Slide softly the slide switch knob by a screw driver to ON or OFF position.

[Note]

The performance can not be assured if the switch knob stays halfway or is changed over to a wrong mode position. Change over the switch knob to a set position without fail.

- ④ Attach the transparent cover again.

(4) Grounding

Ground as following to operate the earth leakage relay certainly.

■ Grounding of the machine

Ground the grounding terminal for earth leakage relay and case grounding terminal according to the below.

① Grounding of the grounding terminal for earth leakage relay

If grounding described below does not comply with the local rule, stricter of the two shall apply.

Use the grounding wire which sectional area is 5.5mm^2 or larger.

Usually it is possible that using attached grounding rod. But if grounding resistance is over $100\ \Omega$, provide the grounding rod which surface area contacted the ground is large.

② Grounding of the case grounding of the machine

Grounding the case grounding of the machine is refer to 「4-4 (1) Case grounding of the machine See p.32」.

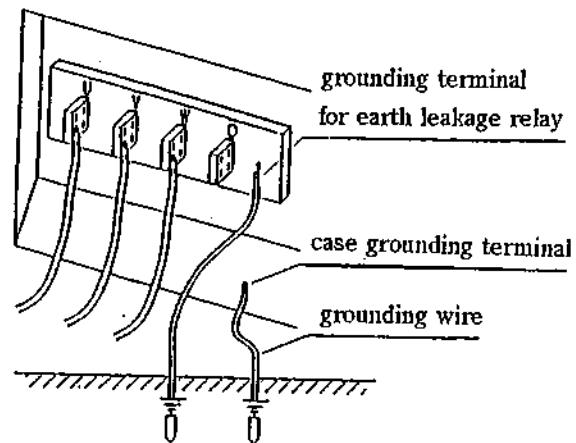

■ Grounding of the load equipment

As in the case of the machine, execute grounding work on the load equipment case. Provide the grounding rod to satisfy the grounding resistance which conforms to the local rule.

[Note] The installation of a leakage relay on the machine can not become a reason for elimination of the need for the load side grounding.

The load side grounding is indispensable for earliest possible detection of any leakage caused in the generator. The absence of such grounding requires any leakage to be detected by current flowing through the human body and is very dangerous because the sensitivity of leakage relay provided on the machine is not sufficient for detection of such current.

■ Precaution in grounding

Precaution in grounding is refer to 「 4-4 (3) Precaution in grounding See p.33 」 .

■ Operation check

For safety reasons, check on the operation of the leakage relay at the startup of the machine according to the procedure described below:

- ① Start up the machine according to 「 5-2 Startup See p.40 」
- ② Make sure that all breakers of the load side are OFF.
- ③ Set the breaker of the machine to ON.
- ④ Press the test button on the leakage relay.
If this causes the lamp (red) on the leakage relay to go on and the breakers to be activated, the leakage relay can be regarded as operating normally.
- ⑤ Press the reset button and return the breaker to the OFF position. This allows the breaker to be turned to ON again.

The leakage relay, once it is activated, holds its activated state until the reset button is pressed or the machine is stopped.

Pilot lamp (green) Earth leakage lamp (red)

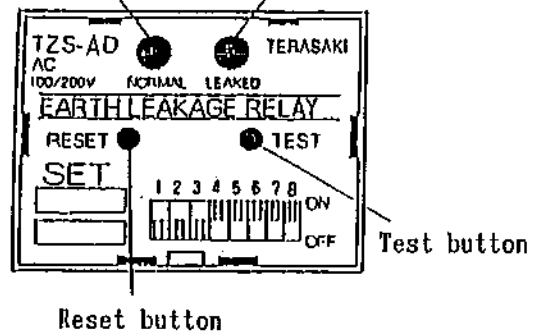

(4) Action for operation of the leakage relay

When the leakage relay is activated, then stop the engine, and measure the insulation resistance several parts and repair the leak spot before restart the engine.